



# ASSEMBLY INSTRUCTIONS

Description: Tristan Dining Chair



## Important safety instructions:

- Please read carefully all instructions before assembly.
- For your safety and ease, assembly by two or more adults is recommended.
- Keep instructions for future use.



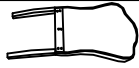

## Pre-assembly:

- Do not discard any content until assembly is complete to avoid accidentally discarding small parts or hardware.
- Take out all parts and hardware from box.

## Parts List

Item	Description	QTY
P1	Chair Back 	1
P2	Seat Cushion 	1
P3	Front Legs 	2

## Hardware List

Item	Description	QTY
H1	Short Bolts Ø5/16"*2" 	5
H2	Long Bolts Ø5/16"*3-1/2" 	4
H3	Lock Washers 5/16" 	9
H4	Flat Washers 5/16" 	9
H5	Allen Wrench 5/16" 	1

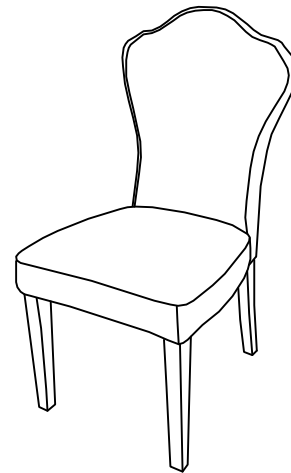



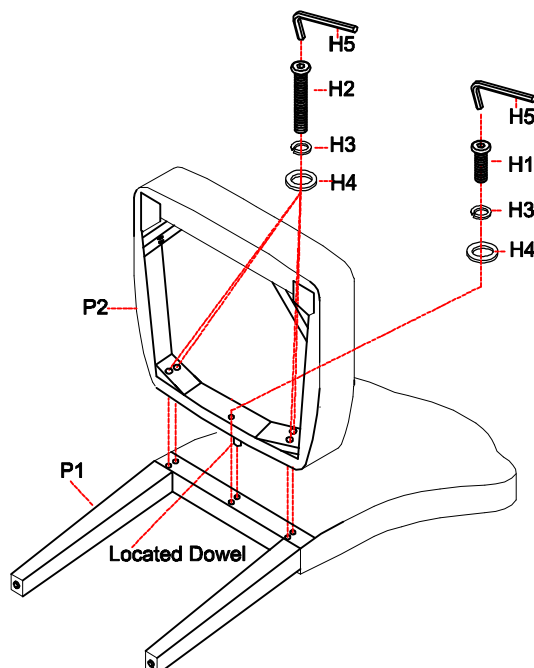

## Assembly Procedures:

**Step 1. Assemble the chair on a flat, soft surface such as a carpet or cloth to prevent scratching the finish. Attach the seat cushion (P2) to the chair back (P1) as shown below.**

- (H1)x1 Short Bolts Ø5/16"\*2" 
- (H2)x4 Long Bolts Ø5/16"\*3-1/2" 
- (H3)x5 Lock Washers Ø5/16" 
- (H4)x5 Flat Washers Ø5/16" 
- (H5)x1 Allen Wrench Ø5/16" 



Step 2. Attach the front legs (P3) to the seat cushion (P2) as shown below.

- (H1)x4 Short Bolts Ø5/16"\*2" 
- (H3)x4 Lock Washers Ø5/16 
- (H4)x4 Flat Washers Ø5/16 
- (H5)x1 Allen Wrench Ø5/16 

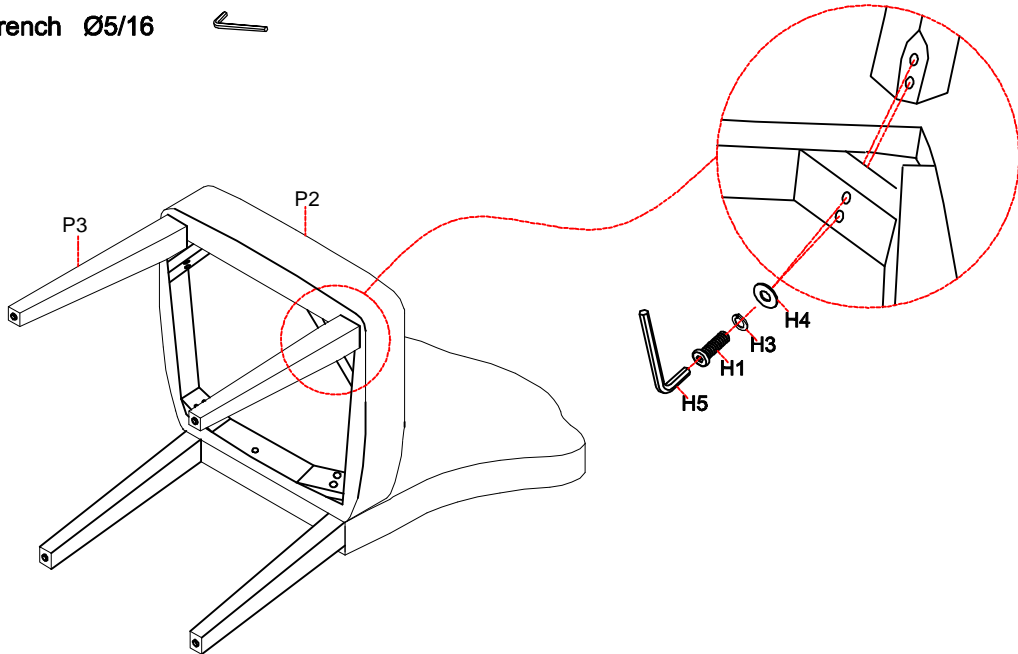

Step 3. Securely tighten all bolts with Allen wrench(H5). Turn the assembled chair to an upright position, make sure the chair is level, aligned properly. Assembly is complete. **Failure to follow these instructions may cause the bolts to misalign during assembly.**

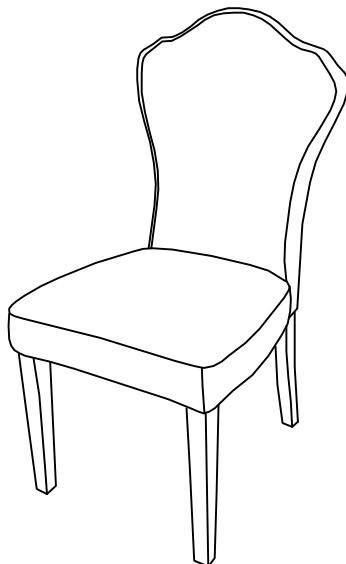

ADDITIONAL NOTE ABOUT SAFETY: BOLTS MAY LOOSEN DURING NORMAL EVERYDAY USE. THEY SHOULD BE PERIODICALLY INSPECTED AND RE-TIGHTENED TO PREVENT DAMAGE OR INJURY. ALWAYS CHECK TO ENSURE THAT ALL HARDWARE IS KEPT TIGHTENED.

**Thank you for your purchase**