

# ASSEMBLY INSTRUCTION

MADE IN CHINA

D109-24/30

Thank you for purchasing this quality product. Be sure to check all packing materials carefully for small parts that may have come loose inside the carton during shipment.

**Before you start assembly:** Please read all instructions carefully before beginning the assembly process.

It is recommended that 2 people work together during assembly to prevent personal injury and to ensure that heavy or cumbersome parts are not damaged during the process.

**CAUTION:** For your safety, this product requires two people to lift.

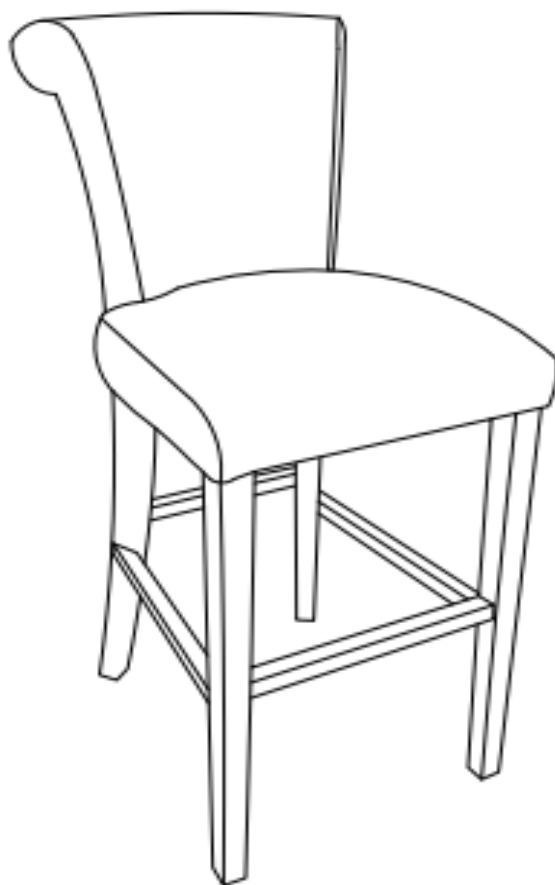

**7** MINUTES

APPROXIMATE ASSEMBLE TIME

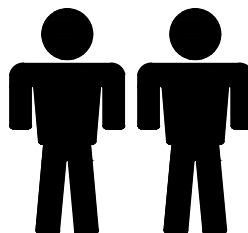

2 PERSONS

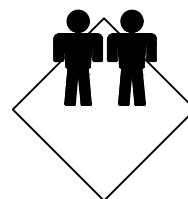



REQUIRED ASSEMBLY SPACE

# ITEM NO.:D109-24/30

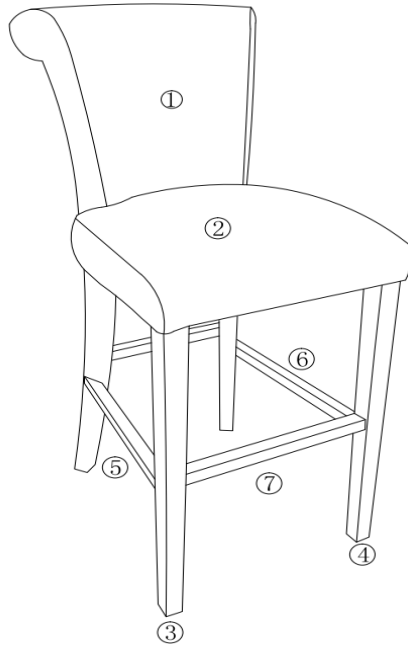
## PART LIST

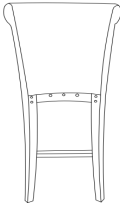
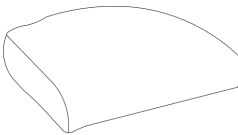

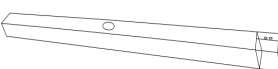
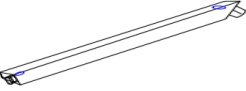
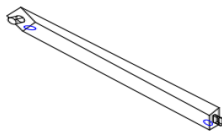
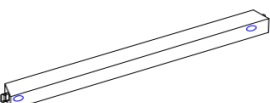
NO.	PICTURE	PARTS DESCRIPTION	Q'TY
<b>1</b>		CHAIR BACK	<b>1</b>
<b>2</b>		SEAT FRAME	<b>1</b>
<b>3</b>		LSF FRONT LEG	<b>1</b>
<b>4</b>		RSF FRONT LEG	<b>1</b>
<b>5</b>		LEFT SIDE STRETCHER	<b>1</b>
<b>6</b>		RIGHT SIDE STRETCHER	<b>1</b>
<b>7</b>		FRONT STRETCHER	<b>1</b>

# ITEM NO.:D109-24/30

## HARDWARE LIST

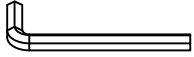

1x

Ø 5/16"x2"

A

Allen Key



1x

2-3/4"

B

Screw Driver



2x

Ø 5/16"x1-1/5"

C

Tenon



8x

Ø 5/16"-2-1/2"

D

Bolt A



1x

Ø 5/16"-2"

E

Bolt B

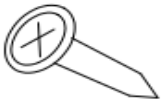

6x

Ø 1/5"x1-3/5"

F

Screw

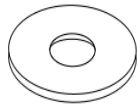

9x

Ø 1/4"

G

Flat Washer



9x

Ø 1/5"

H

Spring Washer

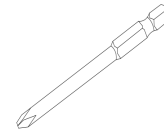

1x

Ø 5/16"-2.9"

I

Straight Allen Key

NOTE: Straight Allen Key(I) is for use with a power drill.

### STEP 1

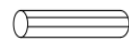
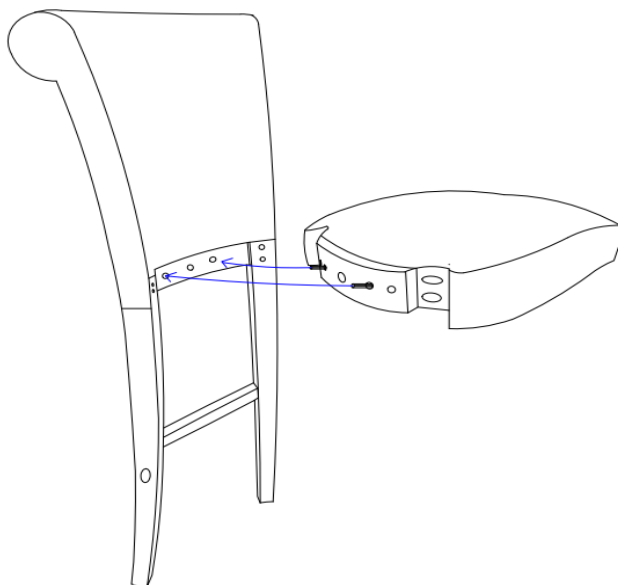

2x

C

Align the seat frame(2) to chair back(1) by using the location tenon (C) to make sure the holes are in position.

## STEP 2

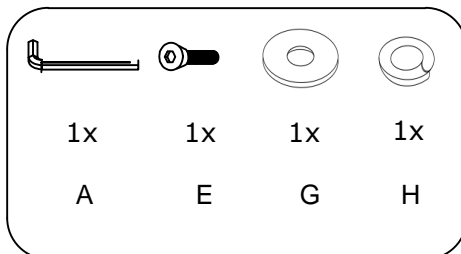
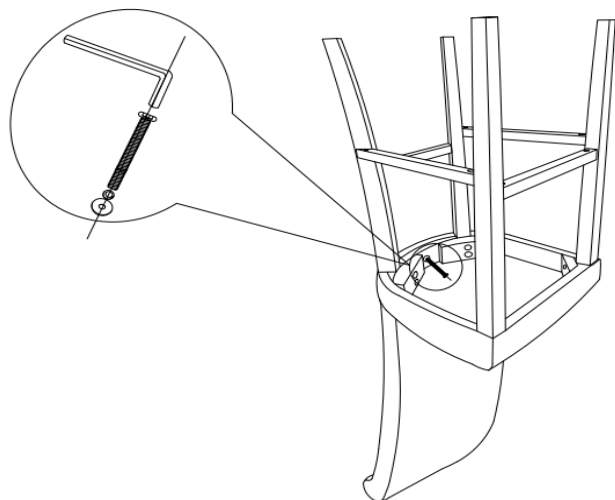

1. Firstly, put the spring washer(H) and flat washer (G) onto bolt(E).

2. Then insert the bolt(E) into the hole with Allen Key(A) or power drill, but do not tighten.

Note: tighten the bolts at last step.

## STEP 3

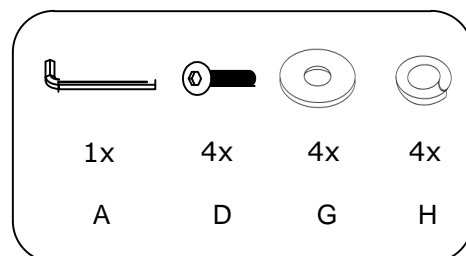
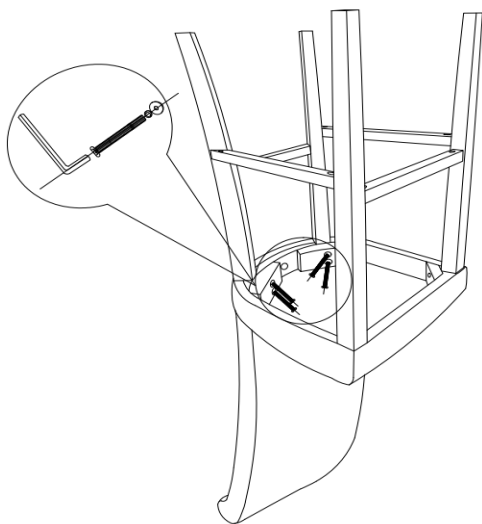

Repeat the same way to attach the rest of bolts(D) with spring washer(H) and flat washer(G) to the chair back.

## STEP 4

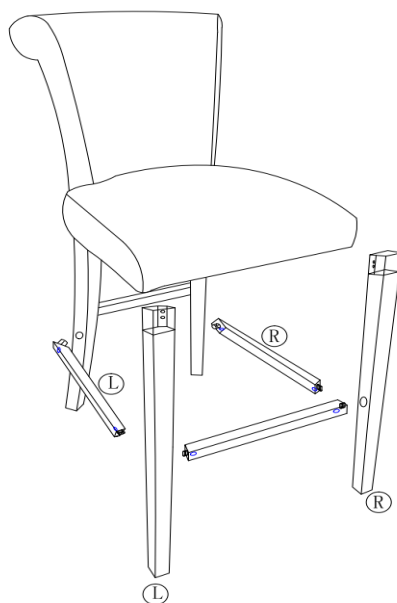

Insert the LSF leg & RSF leg (3&4) into the seat frame with the front stretcher(7), attach the the front legs to chair back(1) with left side stretcher(5) and right side stretcher(6).

Note: The parts are labelled with "L" & "R".

### STEP 5

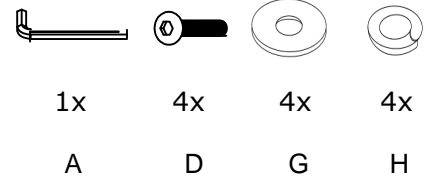
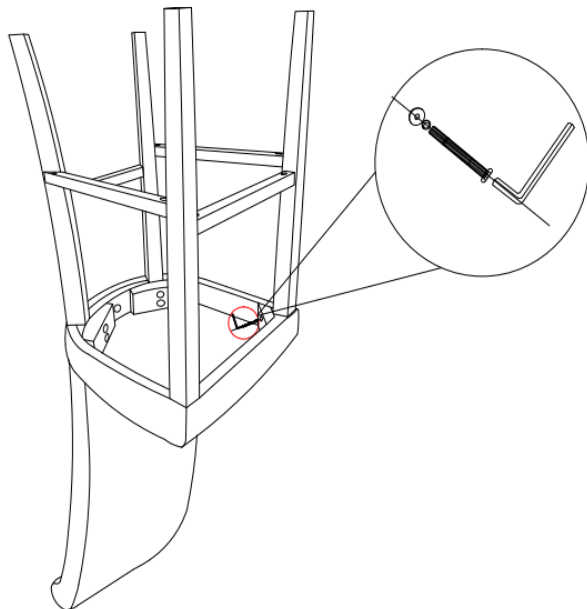

Attach the RSF front leg (4) and LSF front leg (3) to the seat frame (2) by using spring washer (H) and flat washer (G), bolt (D) with Allen wrench (A) or power drill.

### STEP 6

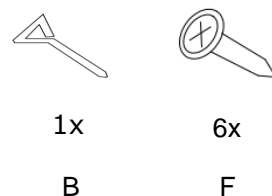
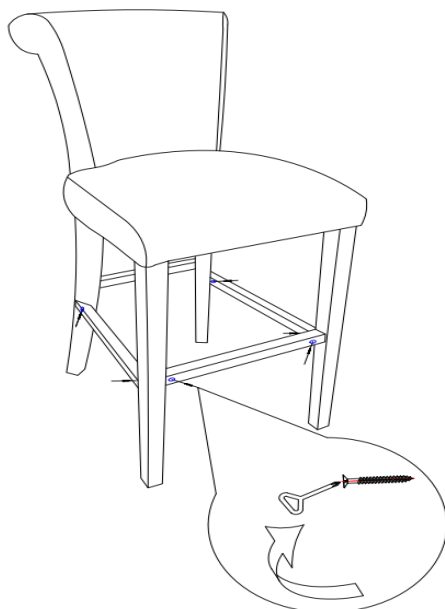

Tighten all the screws (F) on the stretchers with screwdriver (B) or power drill.

### STEP 7

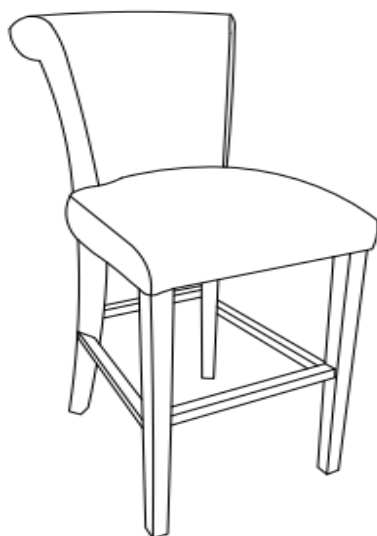

Check that all parts are secured. Turn the barstool upside on a level place to make sure all the legs are level, then tighten all the parts, including the bolts and screw. Assembly completes.

Need Assistance? Call us at 1-855-343-7378 from 8:00am to 5:00 pm PST Monday – Friday