

Assembly Instruction Instructions d'assemblage

STOF **8041-4286L Leg Table**
8043-4286L Leg Table

SKU# 42180416
SKU# 42180430

WARNING: To avoid alignment issue, please don't tighten the screws unless all legs are adjusted at the same level.

Step	Code	HARDWARE LIST / LISTE DE QUINCAILLERIE	QTY' / QTÉ
1	A	Flat Washer Ø5/16"x 3/4" Rondelle plate Ø5/16"x 3/4"	8 PCS 8 Pièces
	B	Spring washer Ø5/16"x 1/2" Rondelle de ressort Ø5/16"x 1/2"	8 PCS 8 Pièces
	C	Hex-Nut Ø5/16"x 12mm Ecrou hexagonal Ø5/16"x 12mm	8 PCS 8 Pièces
2	D	Wrench 12x 75mm Clé 12x 75mm	1 PC 1 Pièce

Step	Code	PART LIST/LISTE DE PIÈCES	QTY' / QTÉ
3	E	Table Top Dessus de table	1 PC 1 Pièce
4	F	Legs Pides	4 PCS 4 Pièces

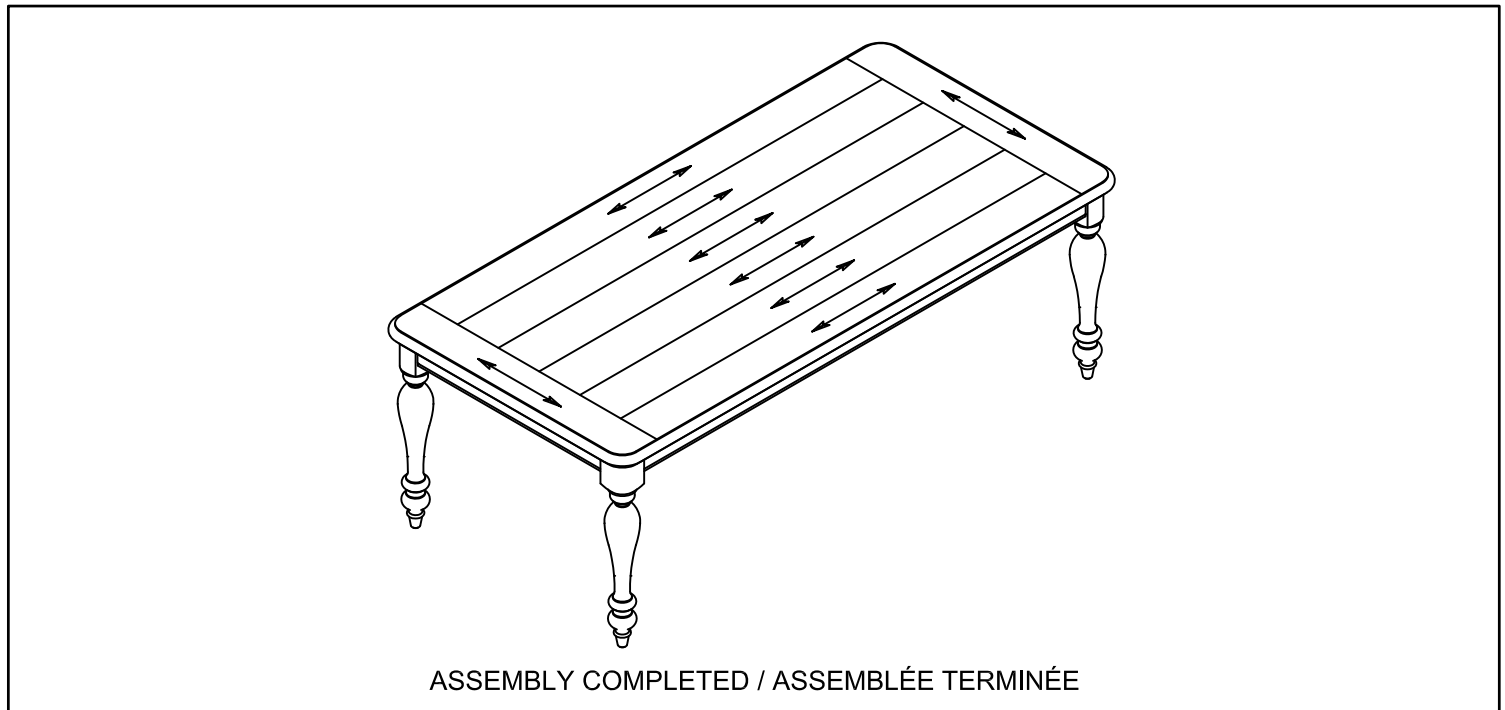

Hardware Pack Location (s):

STOF **8041-4286L Leg Table**
8043-4286L Leg Table

SKU# 42180416
SKU# 42180430

STOF

8041-4286L Leg Table
8043-4286L Leg Table

SKU# 42180416
SKU# 42180430

***Caution: Please read all instructions carefully before starting the assembly process. These parts are cumbersome and heavy. Therefore, two people are recommended in order to prevent personal injury and insure the parts are not damaged during the assembly.

***Avertissement: veuillez lire toutes les instructions attentivement avant de commencer l'assemblage. Ces pièces sont encombrantes et lourdes. Il est recommandé d'être deux personnes pour l'assemblage afin de prévenir des blessures et/ou risquer d'endommager les pièces.

STEP 1

ÉTAPE 1

