

# Assembly Instructions





HMIS 1823-11 Brown Table

SKU # 42218239

HMIS 1825-31 White Pearl Table

SKU # 42218253

\*\*\*Caution: Please read all instructions carefully before starting the assembly process. These parts are cumbersome and heavy. Therefore, two people are recommended in order to prevent personal injury and insure the parts are not damaged during the assembly.

Code	PARTS LIST		
A	Table Top		1Pc
B	Connecting Plate		1Pc
C	Undertop Table Leg		1Pc
D	Bottom Table Leg		1Pc

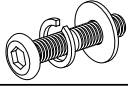
Step	Code	Hardware List		
3	E	Allen Bolt - Ø5/16x18x32mm		6Pcs
		Flat washer - Ø5/16x19x1.5mm		6Pcs
		Lock washer - Ø5/16		6Pcs
1+3+4	F	Allen Key - 4mm		1Pc

## STEP 1

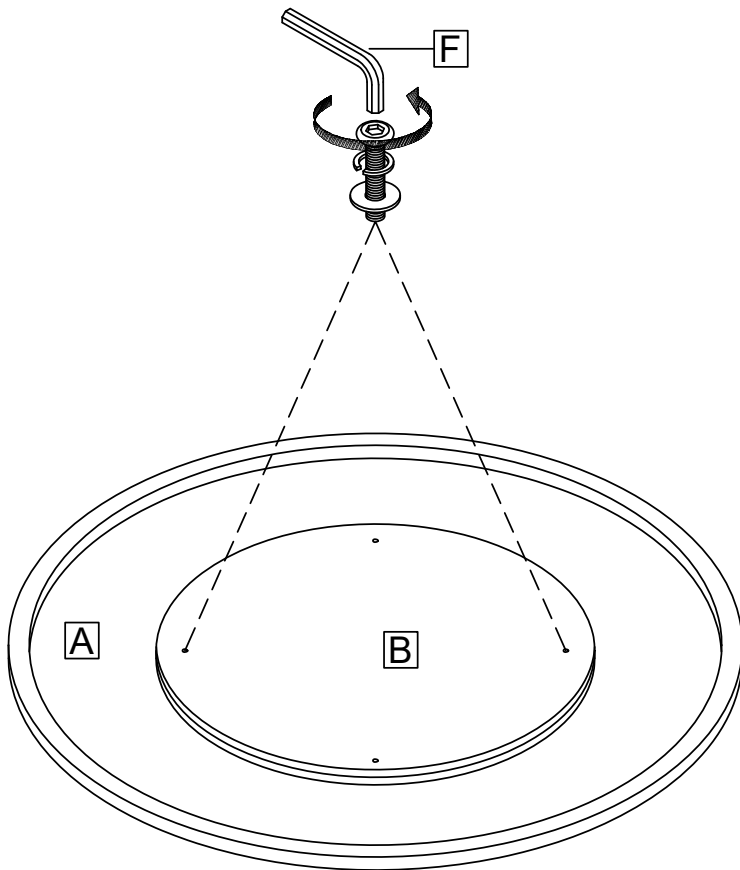

Remove Connecting Plate from the Table Top.

## STEP 2

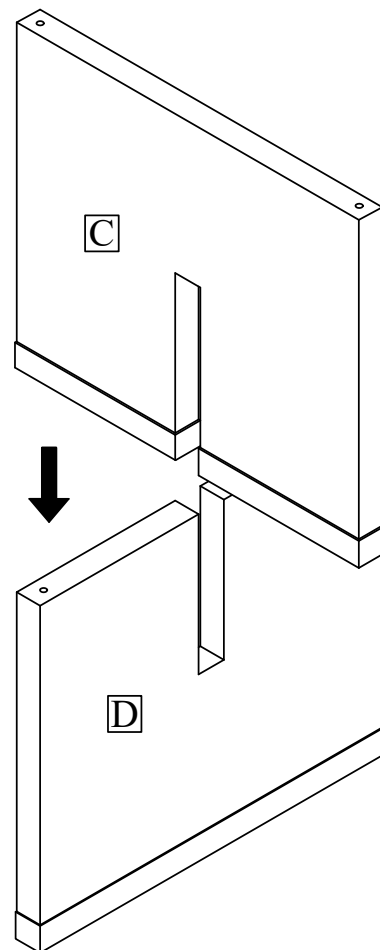

Assemble the two Legs into the X shape like the description above.

This product is manufactured by HMIS for

**ROOMS TO GO** ►

# Assembly Instructions

HMIS 1823-11 Brown Table

SKU # 42218239

HMIS 1825-31 White Pearl Table

SKU # 42218253

STEP 3

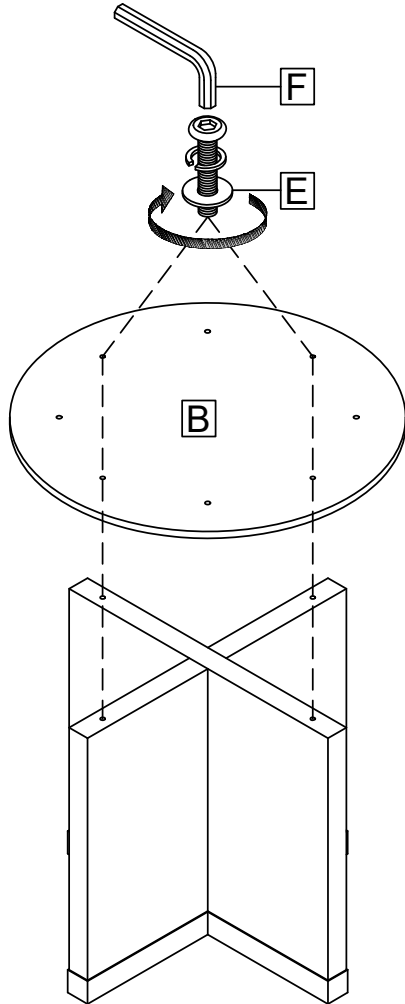

Assemble Table Leg with Connecting Plate.

STEP 4 Assemble Table Leg with Table Top.

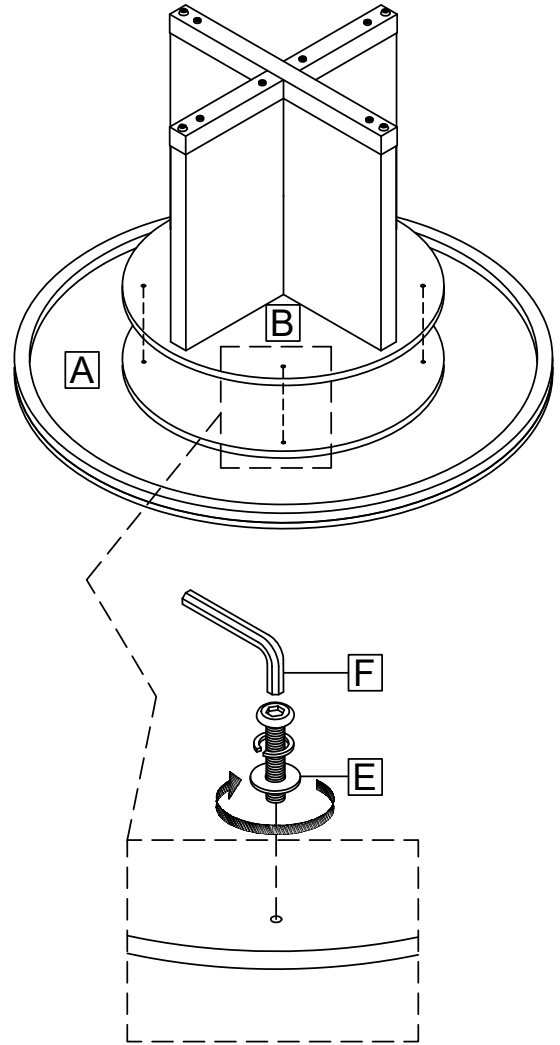

STEP 5

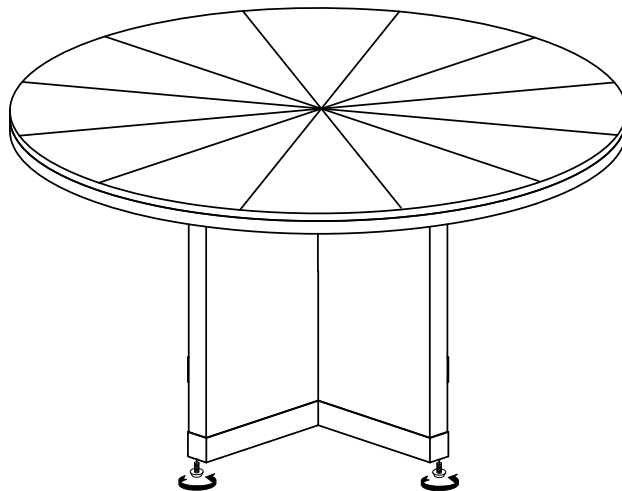

Adjust levelers

This product is manufactured by HMIS for

**ROOMS TO GO** ►

MADE IN VIETNAM

2 OF 2