





ASSEMBLY INSTRUCTION







JSFC

727 / 728-12 SIDE CHAIR

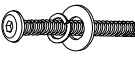
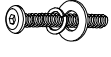
SKU 42407278 / 42407280

Thank you for purchasing this quality product. Be sure to check all packing materials carefully for small parts which may have come loose inside the carton during shipment. Identify and count all parts and compare with the parts list below.

COMPONENT LIST			
NO.	Description	Sketch	Q'TY
A	Back Rest		1pc
B	Seat Cushion		1pc
C	Front Leg - L		1pc
D	Front Leg - R		1pc
E	Stretcher		2pcs

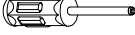
HARDWARE LIST				
NO.	Picture	Description	Dimension	Q'TY
1		Flat Washer	5/16"*22*2mm	8 pcs
		Spring Washer	5/16"*12*2mm	8 pcs
		Bolt	5/16"*18*89mm	4 pcs
2		Flat Washer	1/4"*19*2mm	2 pcs
		Spring Washer	1/4"*12*2mm	2 pcs
		Bolt	1/4"*20*32mm	2 pcs
3		Allen Key	4mm	1 pc
4		Flat Washer	5/16"*22*2mm	4 pcs
5		Spring Washer	5/16"*12*2mm	4 pcs
6		Nut	5/16"*12mm	4 pcs
7		Wrench	12*88mm	1 pc
8		Screw	#4 x 45mm	4 pcs
9		Tool Required(not provided)		

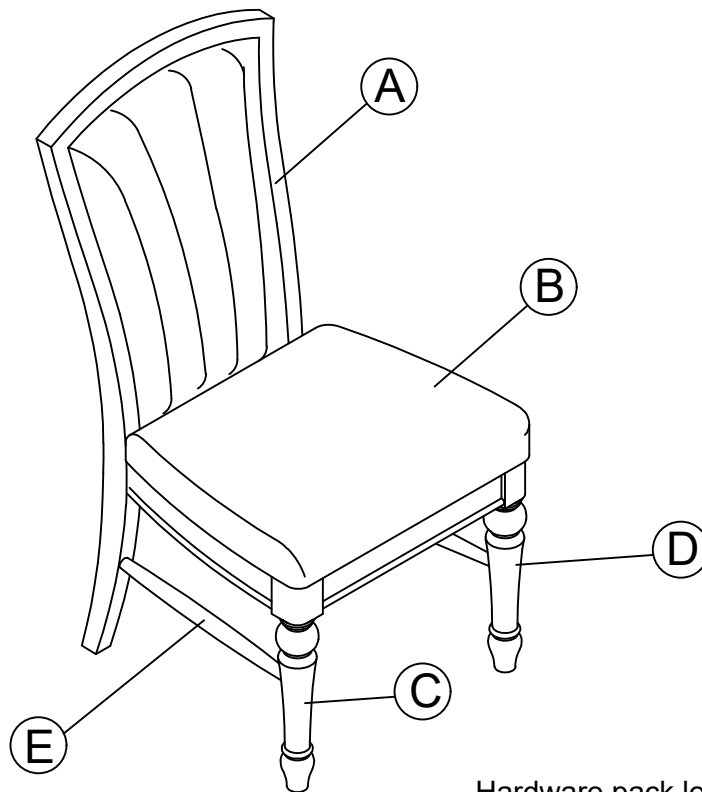

Hardware pack locations

727 / 728 - 12 SIDE CHAIR, SKU# 42407278 / 42407280

PARTS DETAILS

This product is manufactured by JSFC for **ROOMS TO GO** 

ASSEMBLY INSTRUCTION

JSFC

727 / 728-12 SIDE CHAIR

SKU 42407278 / 42407280

STEP 1: Attach the Seat Cushion (B) to Back Rest (A), secure with Flat Washers, Spring Washers and Bolts (2) by using Allen Key (3).

STEP 2: Attach the Seat Cushion (B) to Back Rest (A), secure with Flat Washers, Spring Washers and Bolts (1) by using Allen Key (3).

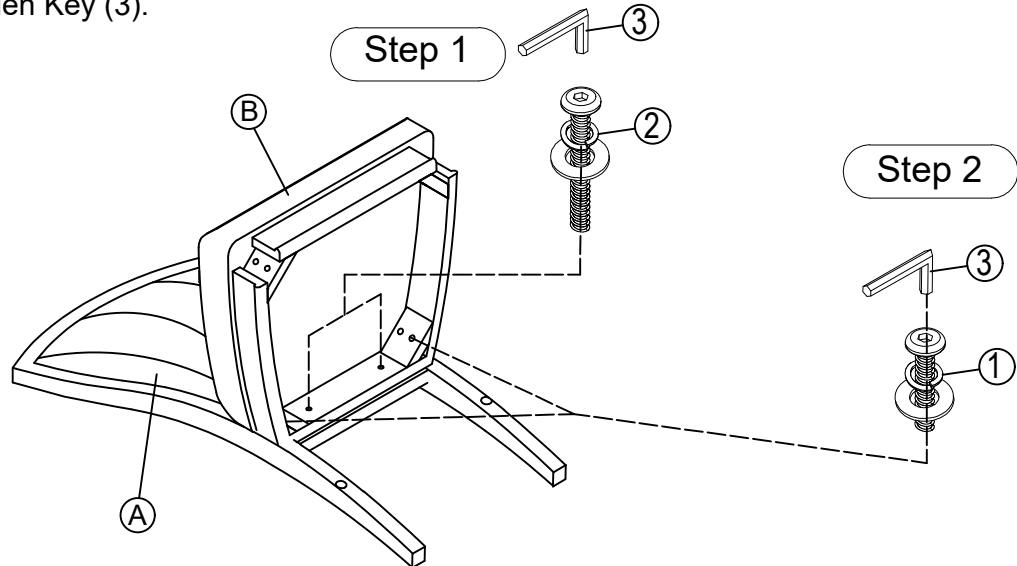

STEP 3: Attach The Front Leg L (C) and Front Leg R (D) to Seat Cushion (B), secure with Flat Washers (4), Spring Washers (5) and Nuts (6) by using Wrench (7).

STEP 4: Attach The Stretcher (E) to Front Leg L/R (C/D) and Back Rest (A), Secure with Screws (8), by using Philips Head Screw Driver (9) (not provided).

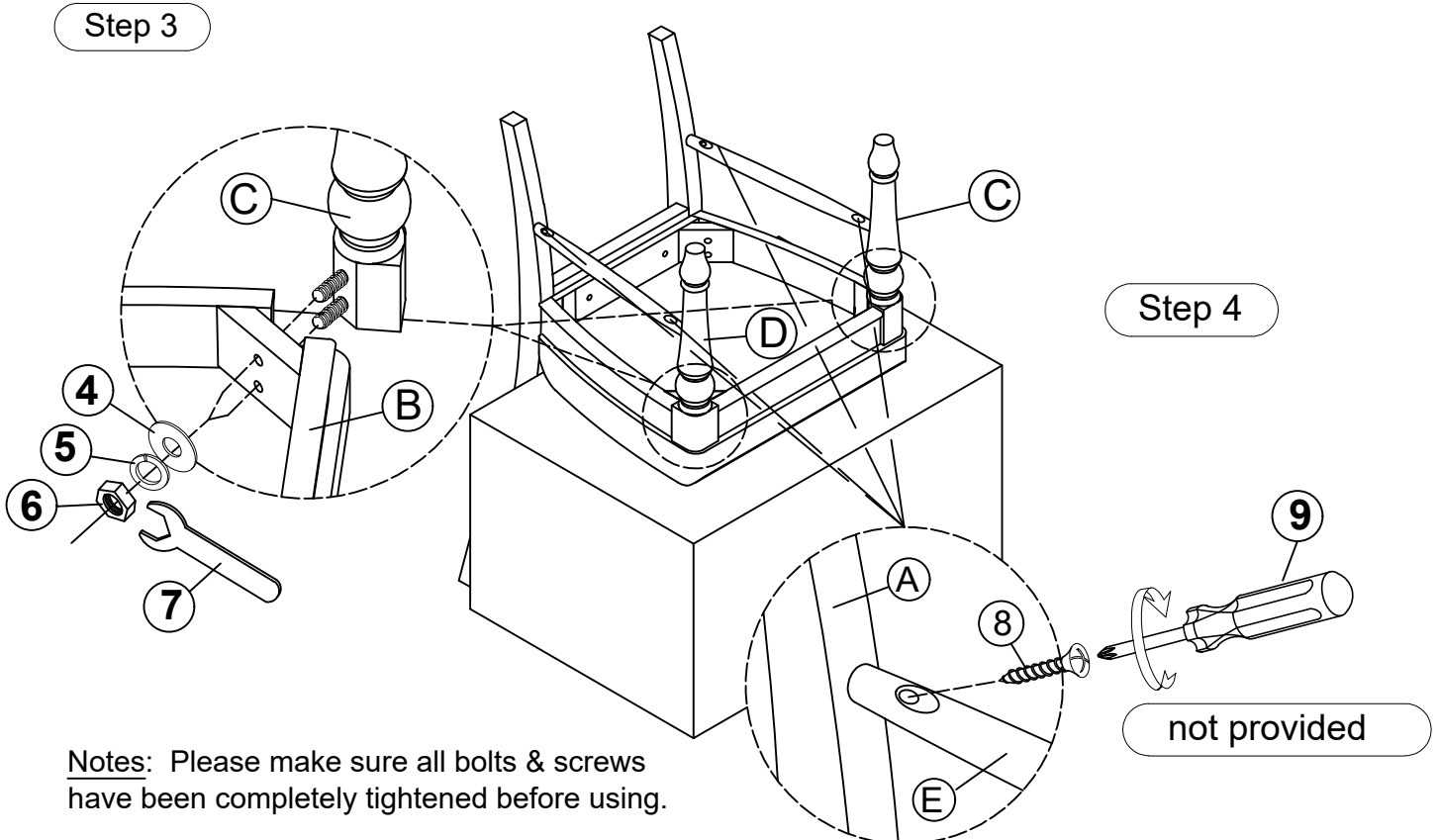

Notes: Please make sure all bolts & screws have been completely tightened before using.

This product is manufactured by JSFC for **ROOMS TO GO** 