



Assembly Instructions





Manufactured By TEAE For Rooms To Go

TEAE 0629-SCBL SIDE CHAIR
TEAE 0629-SCBG SIDE CHAIR
TEAE 0629-SCMU SIDE CHAIR

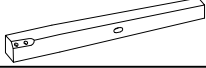
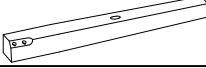

-SKU# 42536295
-SKU# 42636297
-SKU# 42436293

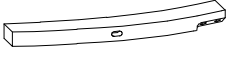
Version 1.0 2025/12/22

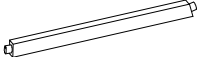
Part list

Step	Part	Description	Photo	Qty
1,2,3,4	A	Seat and back		1 pc
3,4	B	Right front leg		1 pc
3,4	C	Left front leg		1 pc
1,2,3,4	D	Right back leg		1 pc
1,2,3,4	E	Left back leg		1 pc
2,3,4	F	Right stretcher		1 pc
2,3,4	G	Left stretcher		1 pc

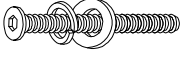
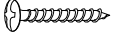
Hardware list

Step	Part	Description	Photo	Qty
1,3	1	Bolt Ø5/16"x18x60mm		8 pcs
		Spring washer Ø5/16"		8 pcs
		Flat washer Ø5/16"		8 pcs
4	2	Wood screw #8x45mm		4 pcs
1,3,5	3	Allen key M4		1 pc
4,5	4	Screwdriver (Not provided)		1 pc

Thanks for purchasing this quality product. Be sure to check all packing materials carefully for small parts, which may have come loose inside the carton during shipment. Identify and count all parts and compare with the Hardware List below.

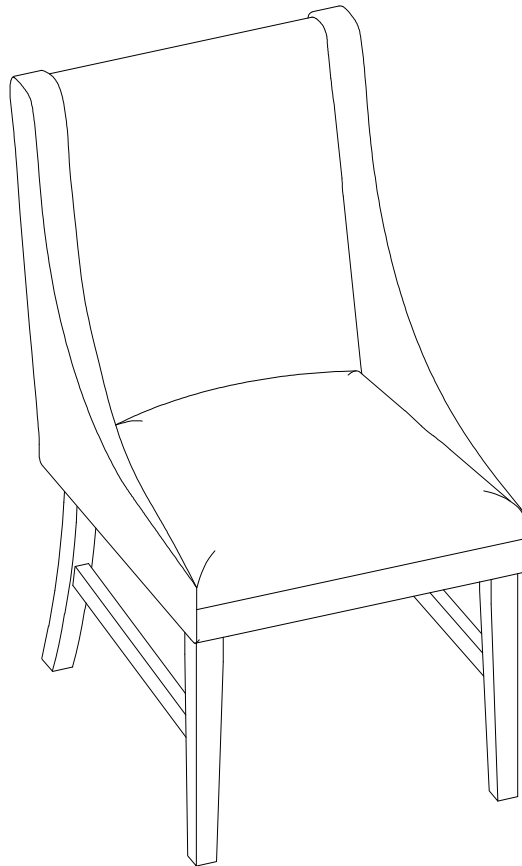

hardware pack locations: TEAE 0629-SCBL SIDE CHAIR
TEAE 0629-SCBG SIDE CHAIR
TEAE 0629-SCMU SIDE CHAIR

-SKU# 42536295
-SKU# 42636297
-SKU# 42436293

STEP 1

Place the back chair (A) on a soft and clean surface.
Assemble the back legs (D,E) with the seat (A) by using allen key (3) with hardware (1).
*Attention: DO NOT TIGHTEN THE BOLTS.

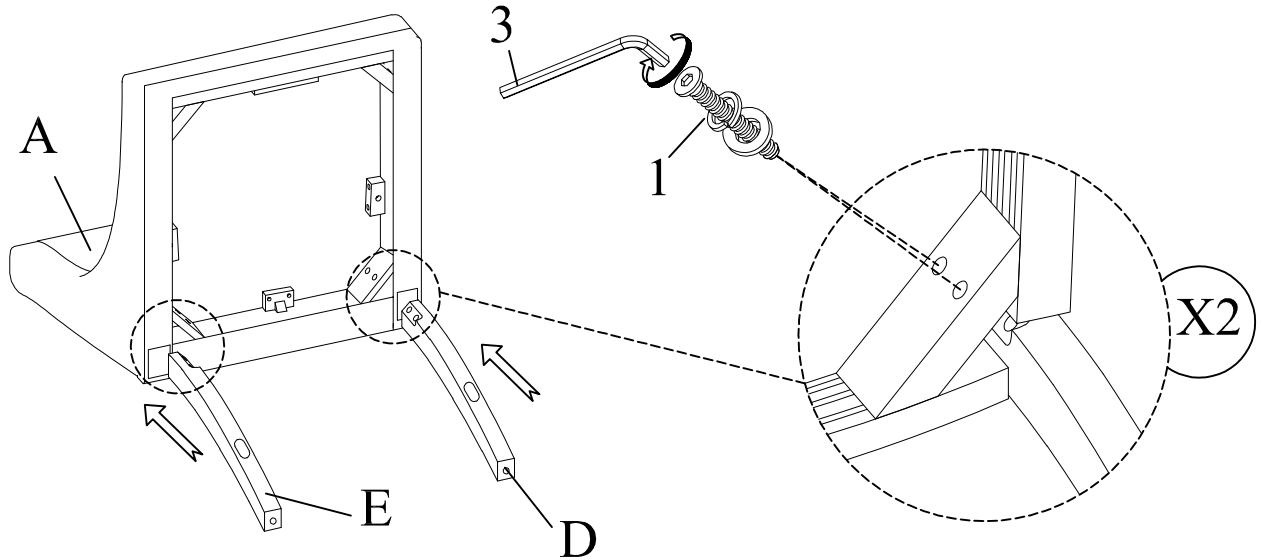

STEP 2

Install the stretcher (F,G) on the back legs (E,D).

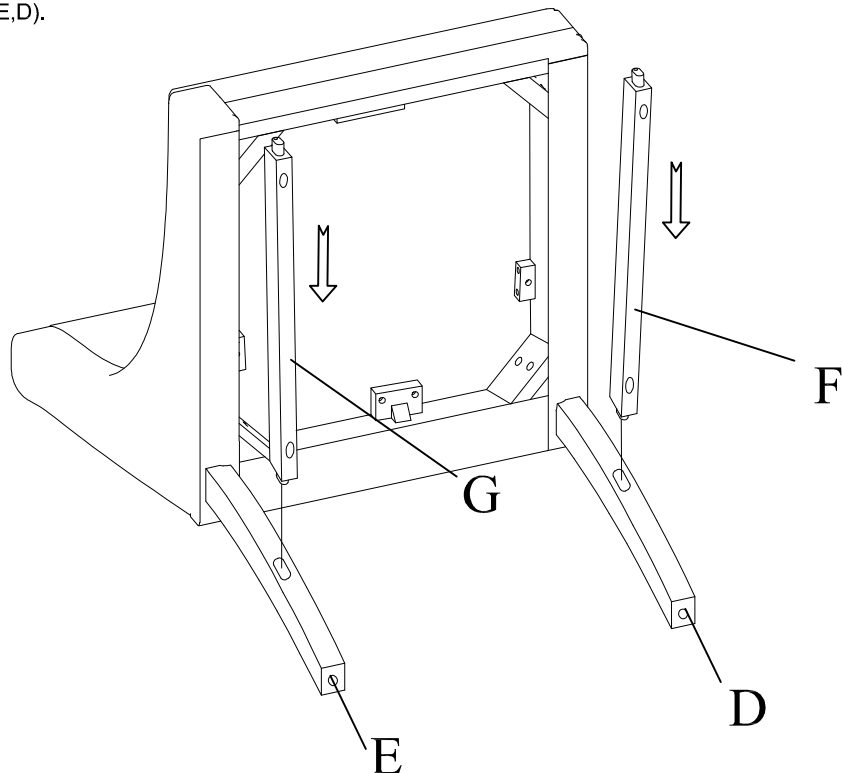

STEP 3

Assemble the front legs (B,C) with the seat (A) by using allen key (3) with hardware (1).

*Attention: DO NOT TIGHTEN THE BOLTS.

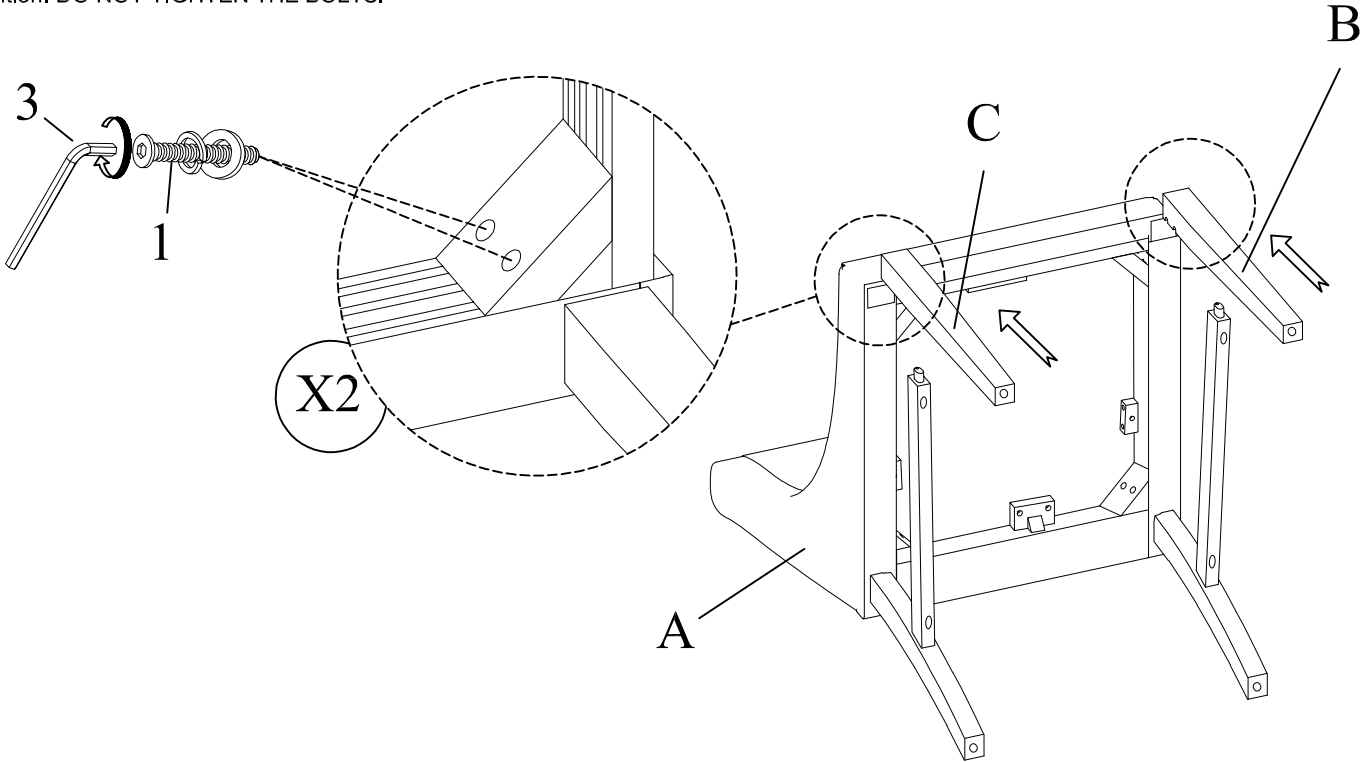

STEP 4

Assemble the stretchers with the front legs (B,C) and the back legs (D,E) by using a screwdriver with hardware (2).

*Attention: DO NOT TIGHTEN THE BOLTS.

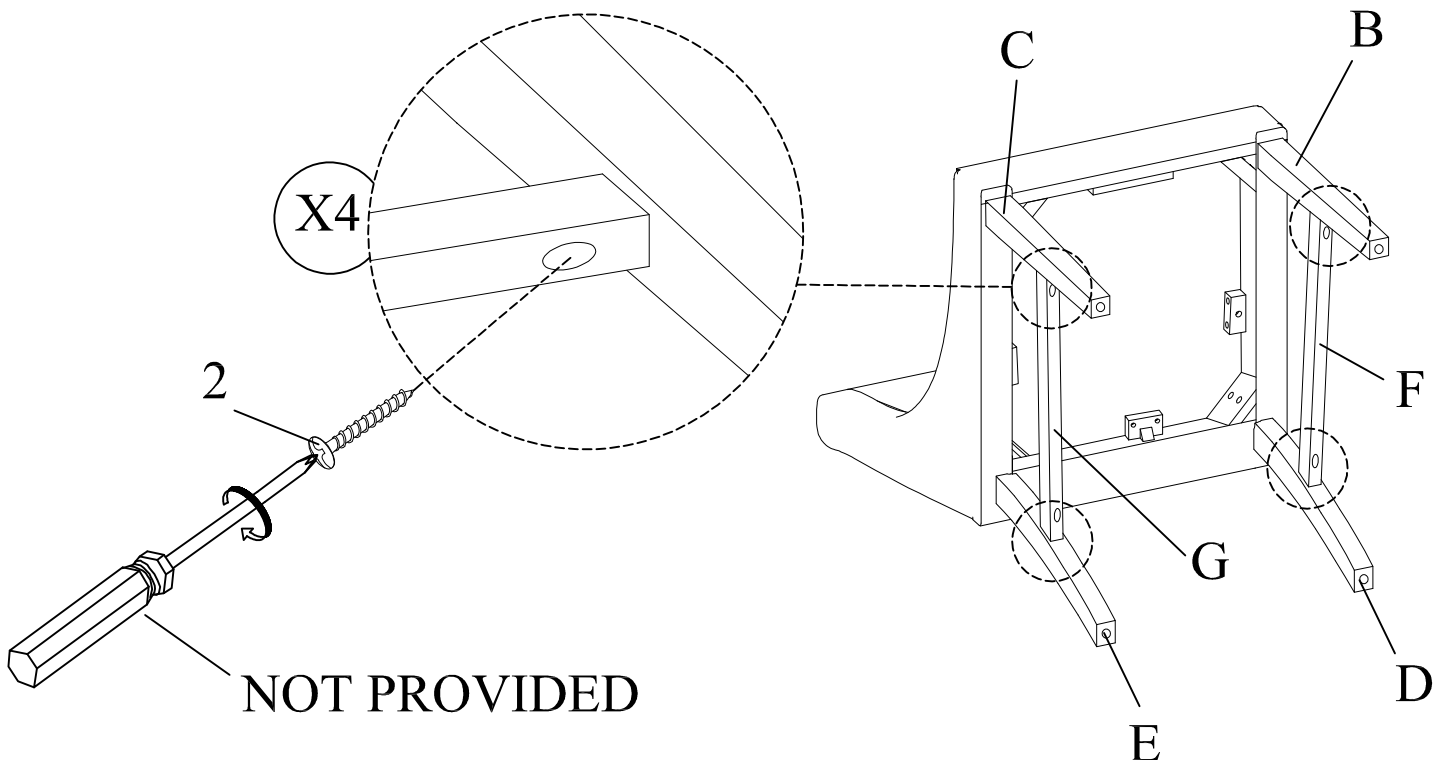



Manufactured By TEAE For Rooms To Go

Assembly Instructions

TEAE 0629-SCBL SIDE CHAIR
TEAE 0629-SCBG SIDE CHAIR
TEAE 0629-SCMU SIDE CHAIR

-SKU# 42536295
-SKU# 42636297
-SKU# 42436293

Version 1.0 2025/12/22

STEP 5

To level the chair, stand the chair up on a flat surface and tighten all the bolts by using allen key (3) and tighten all the screws by using a screwdriver.

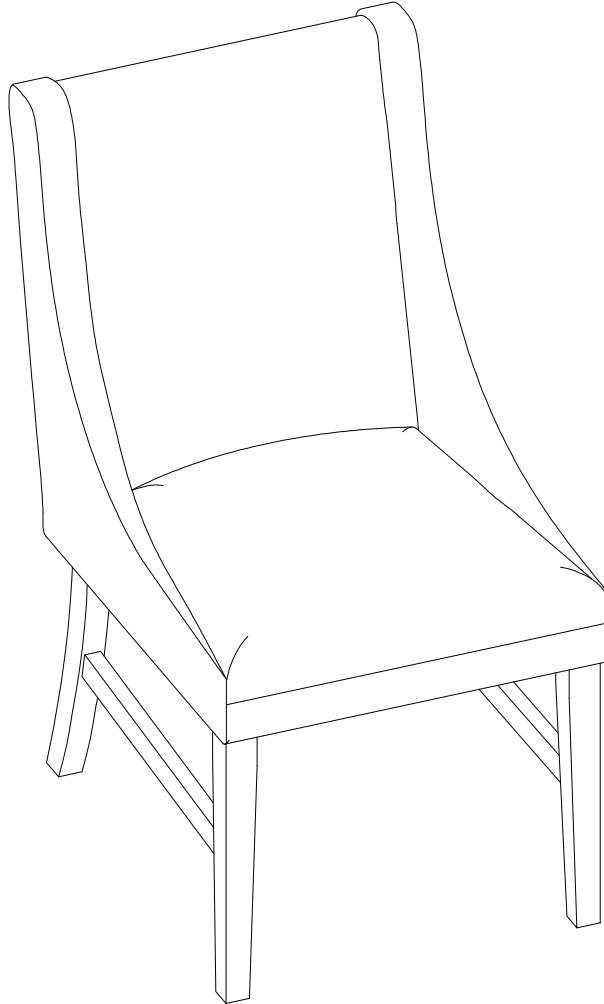

COMPLETE