





ASSEMBLY INSTRUCTIONS

SSIC SKU#: WA500T
SKU#: 42150184

WALDORF DINING TABLE
WALDORF DINING TABLE

WA500T
WA500T

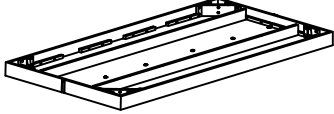
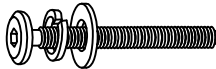
*** Caution. Please read all instructions carefully before starting the assembly process. These parts are cumbersome and heavy. Therefore, two people are recommended in order to prevent personal injury and insure the parts are not damaged during the assembly.

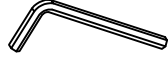
No.	PARTS LIST			No.	HARDWARE LIST		
A		Table Top	1	1		Bolt $\Phi \frac{5}{16}$ " x 60 mm (20 TPI)	8
						Lock Washer $\Phi \frac{5}{16}$ " x 13 mm	8
						Flat Washer $\Phi \frac{5}{16}$ " x 19 mm	8
B		Table Leg	4	2		Allen Key 4 mm	1

Step 1

Place the Table Top (A) upside down on a piece of cloth or carpet to prevent the finish from scratching. Attach the Table Leg (B) to each corner of the Table Top (A) by using Bolt/ Lock Washer/ Flat Washer (1) and tighten with Allen Key (2) provided.

Note: Do not tighten all bolts until the table is fully assembled.

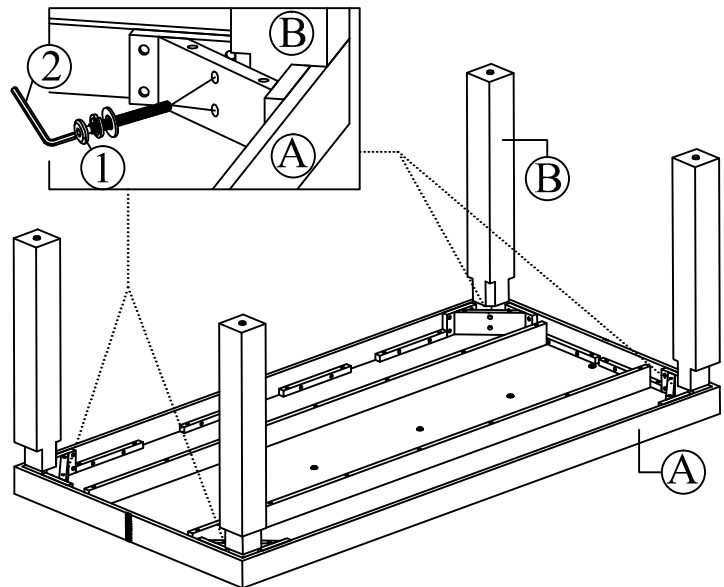

Step 2

Turn the Table to the upright position. Place the Table on a flat surface. Fully tighten all Bolts with Open Wrench (7). The table is assembly completed.

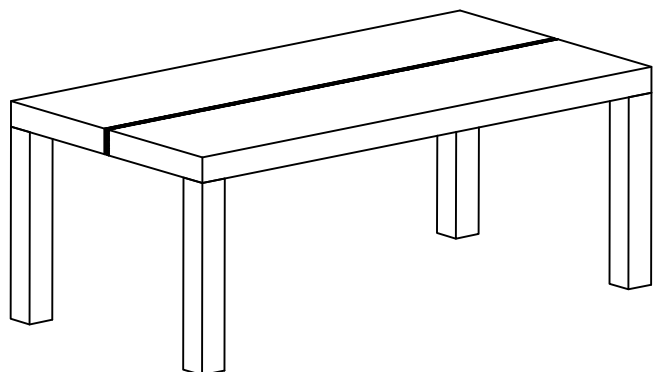

CLEANING INSTRUCTION: Clear with a soft cloth and warm water with a diluted mild detergent. Follow with a soft cloth and clear water rinse. Then dry thoroughly with a soft cloth.

MADE IN VIETNAM







Assembly Instructions



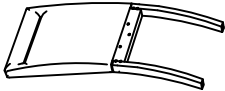

SSIC SKU#: WA500SG
SKU#: 42450180

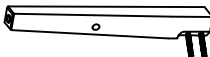
WALDORF SIDE CHAIR
WALDORF SIDE CHAIR

WA500SG
WA500SG

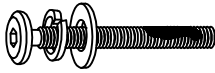
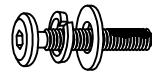
*** Caution. Please read all instructions carefully before starting the assembly process. These parts are cumbersome and heavy. Therefore, two people are recommended in order to prevent personal injury and insure the parts are not damaged during the assembly.

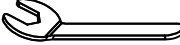
No.	PARTS LIST		
A		Chair Back	1
B		Seat Frame w/Seat Cushion	1
C		Left Front Leg	1
D		Right Front Leg	1
E	 sticker stick under stretcher	Left Side Stretcher	1
F	 sticker stick under stretcher	Right Side Stretcher	1

No.	HARDWARE LIST		
1		Long Bolt $\Phi \frac{1}{4}$ " x 75 mm (20 TPI)	4
		Lock Washer $\Phi \frac{5}{16}$ " x 13 mm	4
		Flat Washer $\Phi \frac{5}{16}$ " x 19 mm	4
2		Short Bolt $\Phi \frac{5}{16}$ " x 40 mm (20 TPI)	3
		Lock Washer $\Phi \frac{5}{16}$ " x 13 mm	3
		Flat Washer $\Phi \frac{5}{16}$ " x 19 mm	3
3		Hex Nut $\Phi \frac{5}{16}$ " x 12 mm	4
		Lock Washer $\Phi \frac{5}{16}$ " x 13 mm	4
		Flat Washer $\Phi \frac{5}{16}$ " x 19 mm	4
4		Wood Screw $\Phi \frac{5}{32}$ " x 40 mm	4
5		Wrench 12 mm	1
6		Allen Key 4 mm	1

Step 1

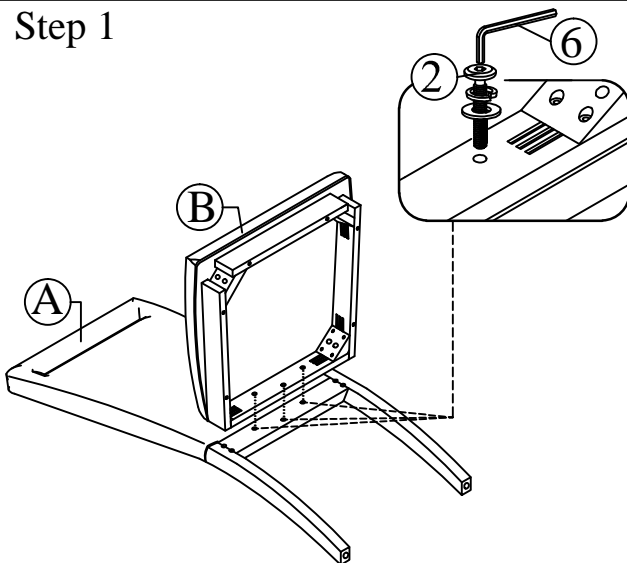

Attach the Seat Frame w/Seat Cushion (B) to the chair backrest of the Chair Back (A) by inserting Short Bolt/ Lock Washer/ Flat Washer (2) and tighten with Allen Key (6).
Note: Do not tighten bolts until the seat is fully assembled.

Step 2

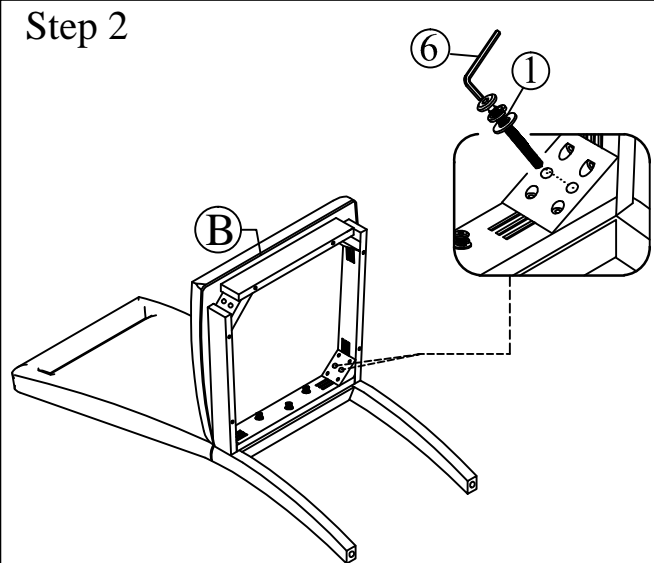

Insert Long Bolt/ Lock Washer/ Flat Washer (1) at the corner to the rear back legs of the Chair Back (A) and tighten with Allen Key (6).
Note: Do not tighten bolts until the seat is fully assembled.

CLEANING INSTRUCTION: Clear with a soft cloth and warm water with a diluted mild detergent.
Follow with a soft cloth and clear water rinse. Then dry thoroughly with a soft cloth.

MADE IN VIETNAM



Assembly Instructions

SSIC SKU#: WA500SG
SKU#: 42450180

WALDORF SIDE CHAIR
WALDORF SIDE CHAIR

WA500SG
WA500SG

*** Caution. Please read all instructions carefully before starting the assembly process. These parts are cumbersome and heavy. Therefore, two people are recommended in order to prevent personal injury and insure the parts are not damaged during the assembly.

Step 3

Attach the Left Front Leg (C) to the seat frame by using Hex Nut/ Lock Washer/ Flat Washer (3), tighten with Wrench (5). Insert the Left Side Stretcher (E) in the middle of the front leg and back leg, and secure the Left Side Stretcher (E) with screws (4) by a Phillips-head screwdriver (not provided).

Note: Do not fully tighten all Hex Nuts & Screws until the chair is fully assembled.

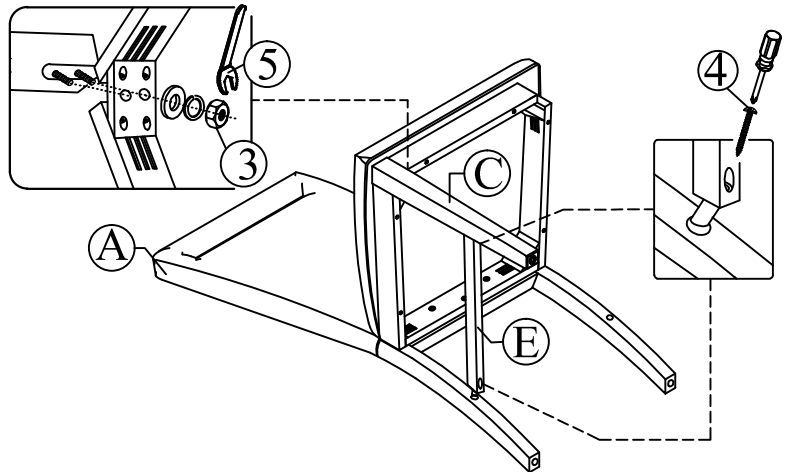

Step 4

Attach the Right Front Leg (D) to the seat frame by using Hex Nut/ Lock Washer/ Flat Washer (3), tighten with Wrench (5). Insert the Right Side Stretcher (F) in the middle of the front leg and back leg, and secure the Right Side Stretcher (F) with screws (4) by a Phillips-head screwdriver (not provided).

Note: Do not fully tighten all Hex Nuts & Screws until the chair is fully assembled.

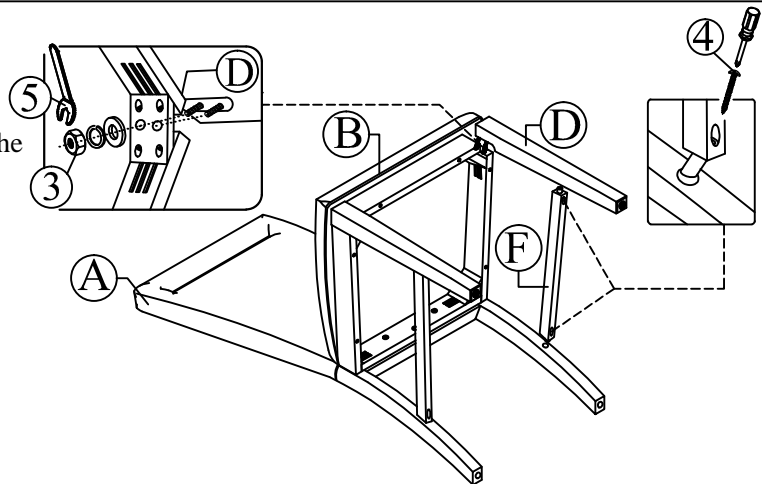

Step 5

Place the chair on a flat surface and adjust the legs so that chair is level and does not wobble. Fully tighten all Bolts and Hex Nuts in steps 3 & 4 with Allen Key (6) and Wrench (5). The chair is assembly completed.

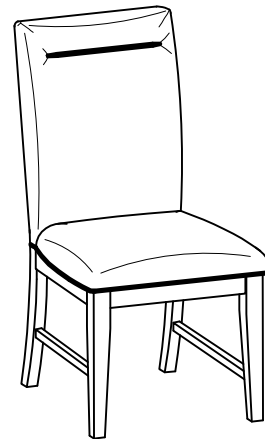

CLEANING INSTRUCTION: Clear with a soft cloth and warm water with a diluted mild detergent. Follow with a soft cloth and clear water rinse. Then dry thoroughly with a soft cloth.

MADE IN VIETNAM



Assembly Instructions

SSIC SKU#: WA500SW
SKU#: 42650184

WALDORF SIDE CHAIR
WALDORF SIDE CHAIR

WA500SW
WA500SW

*** Caution. Please read all instructions carefully before starting the assembly process. These parts are cumbersome and heavy. Therefore, two people are recommended in order to prevent personal injury and insure the parts are not damaged during the assembly.

PARTS LIST				HARDWARE LIST			
No.				No.			
A		Chair Back	1	1		Long Bolt $\Phi 1/4"$ x 75 mm (20 TPI)	4
B		Seat Frame w/Seat Cushion	1			Lock Washer $\Phi 5/16"$ x 13 mm	4
C		Left Front Leg	1			Flat Washer $\Phi 5/16"$ x 19 mm	4
D		Right Front Leg	1	2		Short Bolt $\Phi 5/16"$ x 40 mm (20 TPI)	3
E		Left Side Stretcher	1			Lock Washer $\Phi 5/16"$ x 13 mm	3
F		Right Side Stretcher	1			Flat Washer $\Phi 5/16"$ x 19 mm	3
				3		Hex Nut $\Phi 5/16"$ x 12 mm	4
						Lock Washer $\Phi 5/16"$ x 13 mm	4
						Flat Washer $\Phi 5/16"$ x 19 mm	4
				4		Wood Screw $\Phi 5/32"$ x 40 mm	4
				5		Wrench 12 mm	1
				6		Allen Key 4 mm	1

Step 1

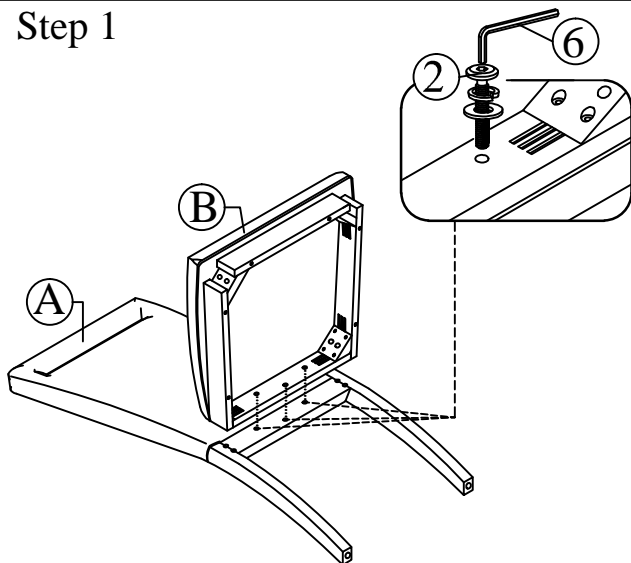

Attach the Seat Frame w/Seat Cushion (B) to the chair backrest of the Chair Back (A) by inserting Short Bolt/ Lock Washer/ Flat Washer (2) and tighten with Allen Key (6).
Note: Do not tighten bolts until the seat is fully assembled.

Step 2

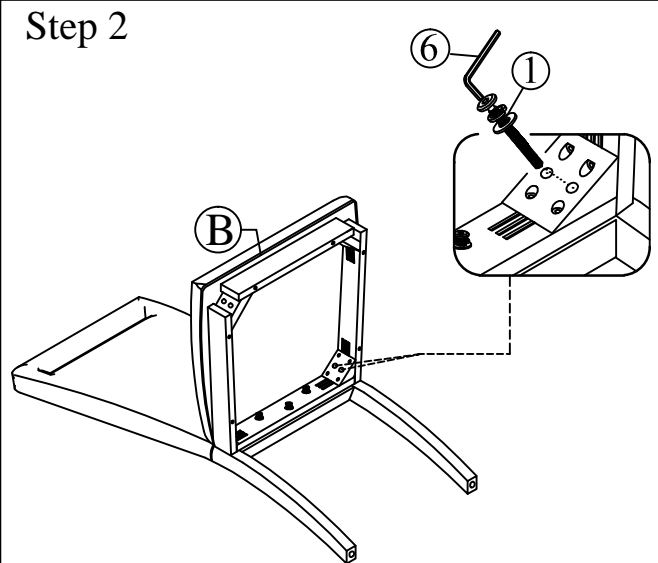

Insert Long Bolt/ Lock Washer/ Flat Washer (1) at the corner to the rear back legs of the Chair Back (A) and tighten with Allen Key (6).
Note: Do not tighten bolts until the seat is fully assembled.

CLEANING INSTRUCTION: Clear with a soft cloth and warm water with a diluted mild detergent.
Follow with a soft cloth and clear water rinse. Then dry thoroughly with a soft cloth.

MADE IN VIETNAM



Assembly Instructions

SSIC SKU#: WA500SW
SKU#: 42650184

WALDORF SIDE CHAIR WHITE
WALDORF SIDE CHAIR WHITE

WA500SW
WA500SW

*** Caution. Please read all instructions carefully before starting the assembly process. These parts are cumbersome and heavy. Therefore, two people are recommended in order to prevent personal injury and insure the parts are not damaged during the assembly.

Step 3

Attach the Left Front Leg (C) to the seat frame by using Hex Nut/ Lock Washer/ Flat Washer (3), tighten with Wrench (5). Insert the Left Side Stretcher (E) in the middle of the front leg and back leg, and secure the Left Side Stretcher (E) with screws (4) by a Phillips-head screwdriver (not provided).

Note: Do not fully tighten all Hex Nuts & Screws until the chair is fully assembled.

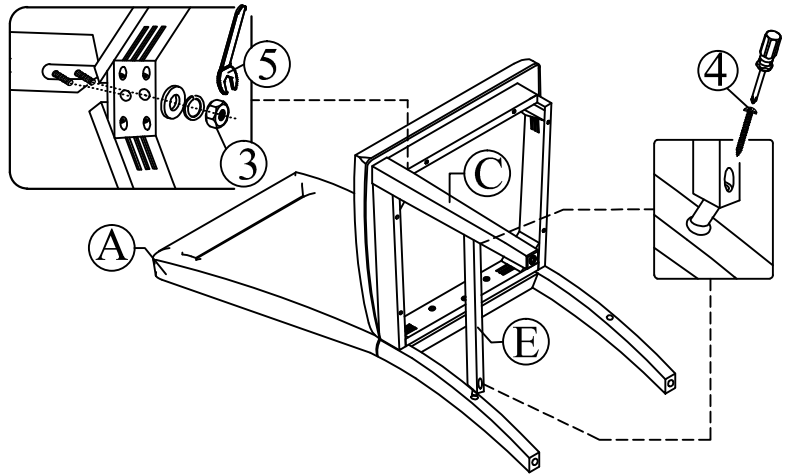

Step 4

Attach the Right Front Leg (D) to the seat frame by using Hex Nut/ Lock Washer/ Flat Washer (3), tighten with Wrench (5). Insert the Right Side Stretcher (F) in the middle of the front leg and back leg, and secure the Right Side Stretcher (F) with screws (4) by a Phillips-head screwdriver (not provided).

Note: Do not fully tighten all Hex Nuts & Screws until the chair is fully assembled.

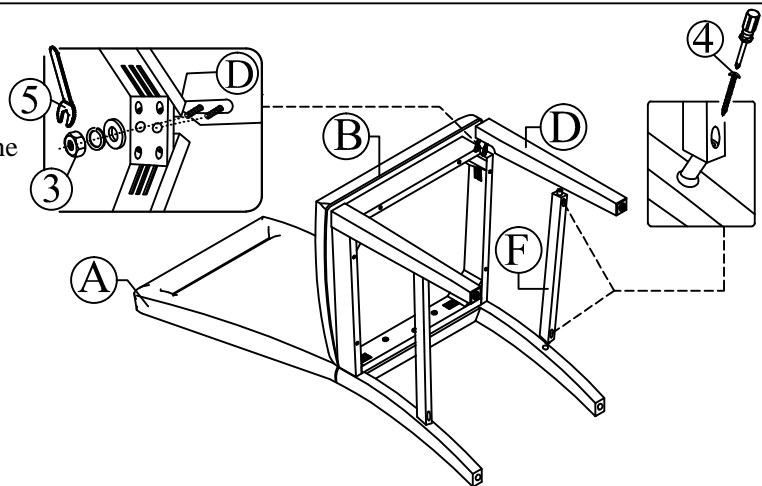

Step 5

Place the chair on a flat surface and adjust the legs so that chair is level and does not wobble. Fully tighten all Bolts and Hex Nuts in steps 3 & 4 with Allen Key (6) and Wrench (5). The chair is assembly completed.

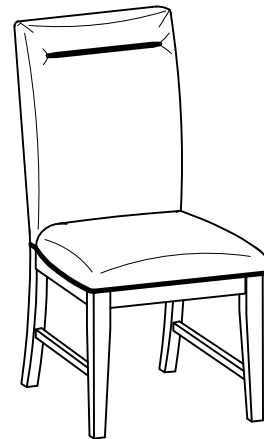

CLEANING INSTRUCTION: Clear with a soft cloth and warm water with a diluted mild detergent. Follow with a soft cloth and clear water rinse. Then dry thoroughly with a soft cloth.

MADE IN VIETNAM



ASSEMBLY INSTRUCTIONS



SSIC SKU#: WA500SV
SKU#: 42950180

WALDORF SERVER
WALDORF SERVER

WA500SV
WA500SV

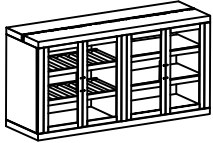
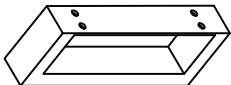
*** Caution. Please read all instructions carefully before starting the assembly process. These parts are cumbersome and heavy. Therefore, two people are recommended in order to prevent personal injury and insure the parts are not damaged during the assembly.

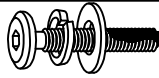
No.	PARTS LIST		
A		Server	1
B		Metal Leg	2

No.	HARDWARE LIST		
1		Allen Bolt $\Phi \frac{1}{4}$ " x 25 mm (20 TPI)	8
		Lock Washer $\Phi \frac{5}{16}$ " x 13 mm	8
		Flat Washer $\Phi \frac{5}{16}$ " x 19 mm	8
2		Allen Key 4 mm	1
3		Tipping Restraint	1 set

Step 1

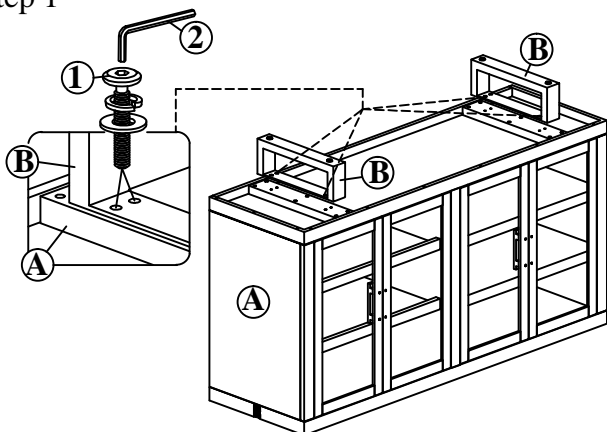

Place the Server (A) upside down on a piece of cloth or carpet to prevent the finish from scratching. Attach the Metal Leg (B) by using Bolt/ Lock Washer/ Flat Washer (1) and fully tighten with Allen Key (2) provided.

Step 2

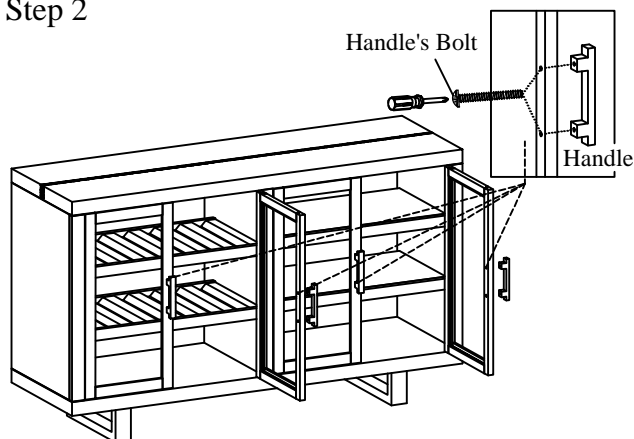

Turn the Server to the upright position. Open the door, attach the Handles from the inside to the outside of the door, and secure the Handle Bolts by a Phillips-head screwdriver (not provided).

Step 3

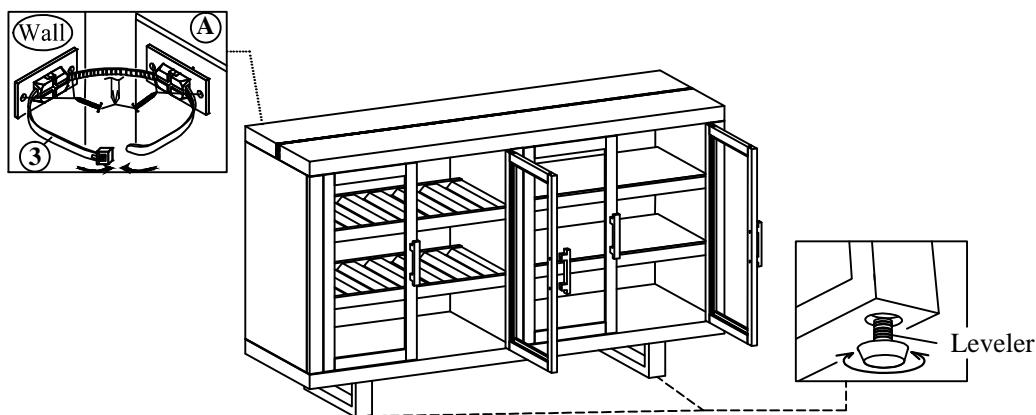

The Tipping Restraint (3) is stapled at the back of Server (A). Thread Tipping Restraint (3) through the Server's slots to fasten and lock as the picture shows. Adjust the Leveler so the Server is level and does not wobble. The server is assembly completed.

CLEANING INSTRUCTION: Clear with a soft cloth and warm water with a diluted mild detergent. Follow with a soft cloth and clear water rinse. Then dry thoroughly with a soft cloth.

MADE IN VIETNAM