

# Assembly instructions for



## Wood Side Chair 8522-251





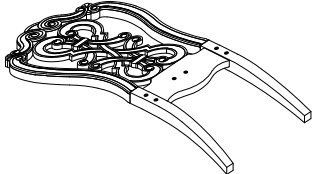
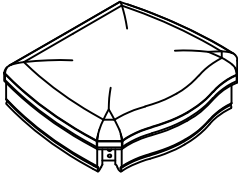

**RIEE: 42452211**

PAGE 1 OF 2

**Caution:** Please read instructions thoroughly before unpacking assembly parts. Sharp, exposed staple tips can cause injury, therefore, for your protection, please remove any exposed staples used in packing.

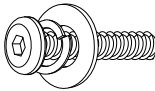
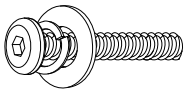
1. We recommend that you should assemble this product with the assistance of another person; this will make assembly easier, and will help to eliminate damage to the product or injury to persons during assembly.
2. Be sure to check all packing materials carefully for small parts that may have come loose inside the carton during shipment.
3. Please do not over tighten screws or bolts.
4. Please put all parts on a non-abrasive floor before assembly, and follow the assembly steps to assemble your newly purchased product correctly and efficiently.

NO.	A	B	C
<b>PARTS LIST (8522-251)</b>			
	CHAIR BACK	CUSHION SEAT	FRONT LEG
<b>Q'TY</b>	1 piece	1 piece	2 pieces

NO.	<b>HARDWARE LIST (8522-251)</b>		<b>Q'TY</b>
1		(Ø5/16*12MM) WRENCH	1 piece
2		(L57*4MM) ALLEN KEY	1 piece
3		(Ø1/4*20*1-3/4") SHORT BOLT	2 pieces
		(Ø1/4*13*1.5MM) SPRING WASHER	2 pieces
		(Ø1/4*19*1.5MM) FLAT WASHER	2 pieces
4		(Ø5/16*18*3-1/4") LONG BOLT	4 pieces
		(Ø5/16*13*1.2MM) SPRING WASHER	4 pieces
		(Ø5/16*19*1.8MM) FLAT WASHER	4 pieces
5		(Ø5/16*13*1.2MM) SPRING WASHER	4 pieces
		(Ø5/16*19*1.8MM) FLAT WASHER	4 pieces
		(Ø5/16*12MM) HEXAGON NUT	4 pieces

# Assembly instructions for

Wood Side Chair 8522-251

RIEE: 42452211

PAGE 2 OF 2

**Step 1** : Unpack carton and place all parts on a non-abrasive floor.

**Step 2** : Remove plastic cover from upholstered seat cushion (B)

**Step 3** : Attach the chair back frame (A) to the Upholstered seat frame (B) by using flat washers, spring washers and short bolts (#3). Do not tighten all bolts until the seat is fully assembled.

Attach the chair back frame (A) to the Upholstered seat frame (B) by using flat washers, spring washers and long bolts (#4) through the pre-drilled holes in the rear corner blocks of the wood seat frame and into the insert nuts on the legs of the chair back frame (A).

Use hand to tighten bolts. (Don't use Allen Key (#2) to tighten the bolts tightly yet.

**Step 4** : Attach front leg (C) to Upholstered seat frame (B) by using flat washer, spring washer and hexagon nut(#5) through the pre-drilled holes in the front corner blocks of the wood seat frame. Then use hand to tighten all nuts securely. (Don't use Wrench (#1) to tighten the nuts tightly yet.

Most floors have slight irregularities that can effect chair leveling. If your chair is uneven when placed in its desired location , please perform the following steps:

1. Loosen all bolts and nuts.
2. Put the chairs at the desired location.
3. Gently push downward on the front of seat and also at the back edge of seat until all four legs rest on floor.
4. Once the chair is level, no wobbly issue, now use Allen key & Wrench to tighten all bolts and nuts securely again.

**Step 5** : Fully tighten all bolts and nuts at this time. Assembly product is now completed.

## Step 3

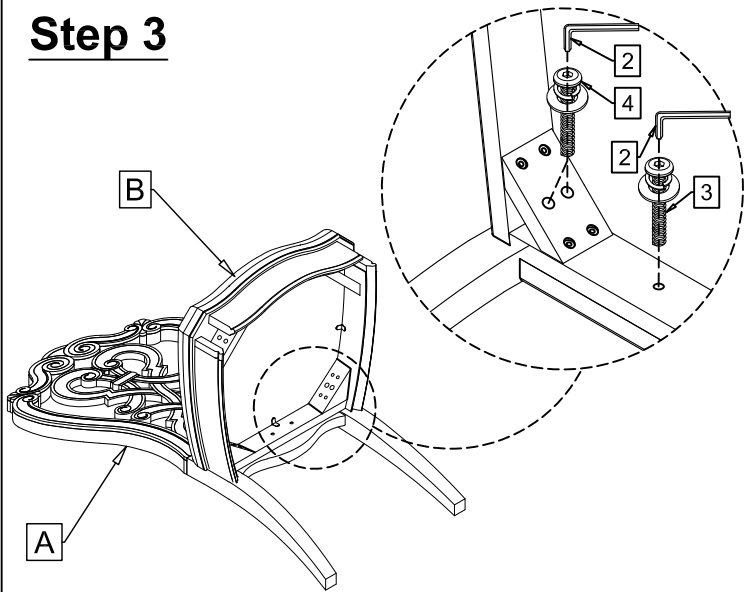

## Step 4

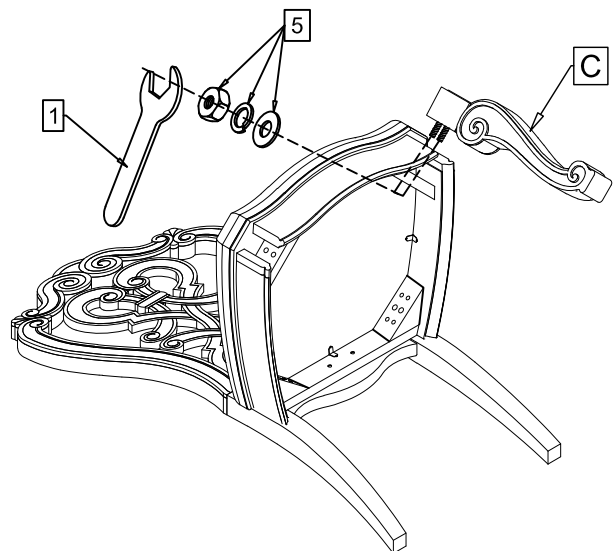

## Step 5

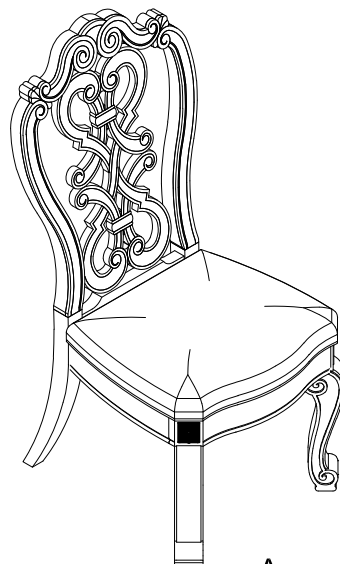

Assembly completed