



# ASSEMBLY INSTRUCTIONS





## LEGC 5413-240 SIDE CHAIR - SKU 42454138

Manufactured by LEGC for ROOMS TO GO

Version 1: 05.09.2025

**Caution:** Please read the instructions thoroughly before unpacking and assembly. Sharp, exposed staple tips can cause injury. Therefore, for your protection, please remove any exposed staples used in the packaging.

1. We recommend that you should assemble this product with the assistance of another person; this will make assembly easier, and will help eliminate damage to the product or injury to persons during assembly.
2. Be sure to check all packing materials carefully for small parts that may have come loose inside the carton during shipment.
3. Please do not over tighten screws or bolts.
4. Please put all parts on a non-abrasive floor before assembly, and follow the assembly steps to assemble your newly purchased product correctly and efficiently.

NO.	PART LIST		Q'TY
A	SEAT FRAME		1 Pc
B	RIGHT LEG FRAME		1 Pc
C	LEFT LEG FRAME		1 Pc
D	FRONT STRETCHER		1 Pc
E	BACK STRETCHER		1 Pc

NO.	HARDWARE LIST		Q'TY
1	Bolt 5/16"-18*2 1/4"		8 Pcs
2	Spring Washer 5/16"		8 Pcs
3	Flat Washer 5/16"*19mm		8 Pcs
4	Allen Key 4mm		1 Pc
5	Wood screw #8*38mm		4 Pcs

**STEP 1:** Lay out all parts and hardware on a clean protective surface to protect the furniture and floor during assembly. Make sure the quantity of each is correct and the feet are free of stain, staples, screws and nail.

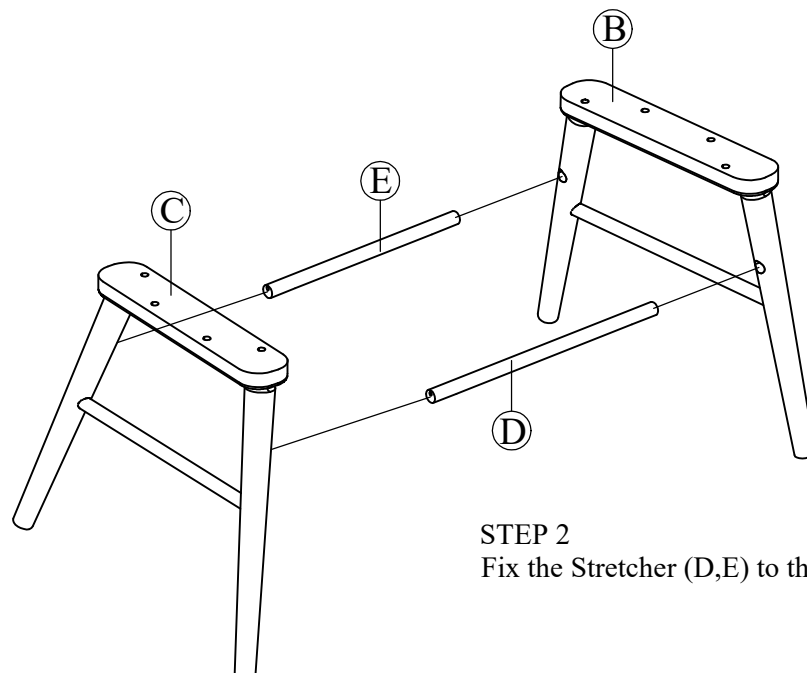

**STEP 2**  
Fix the Stretcher (D,E) to the Left, Right Leg (B,C).



Manufactured by LEGC for ROOMS TO GO

# ASSEMBLY INSTRUCTIONS

## LEGC 5413-240 SIDE CHAIR - SKU 42454138

Version 1: 05.09.2025

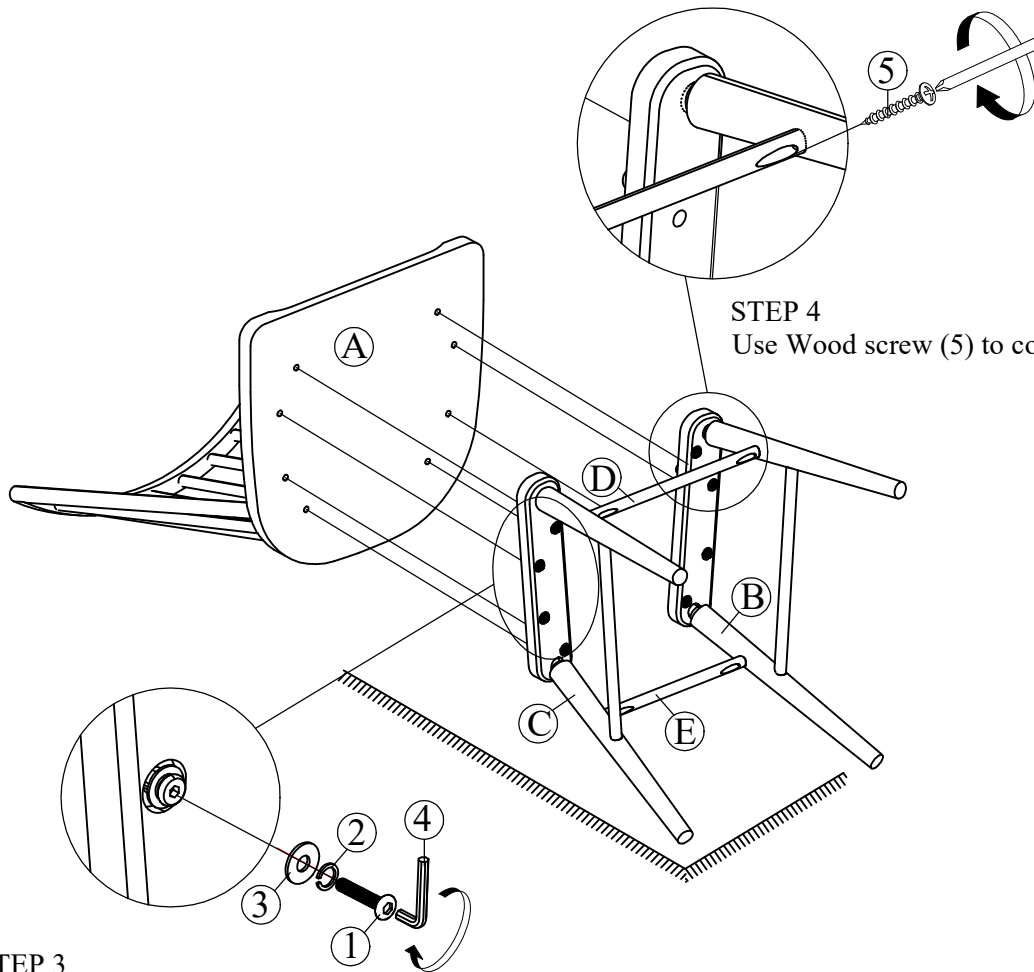

**STEP 4**  
Use Wood screw (5) to connect the Stretcher (D,E).

**STEP 3**  
Attach Seat frame (A) to the Left, Right Leg (B,C) by using hardware (1,2,3,4) as shown .

