







ASSEMBLY INSTRUCTION

SKFR 5678-2 SIDE CHAIR / SKFR 5679-SC SIDE CHAIR
SKU # 42456788 / 42456790

Thank you for purchasing this quality product. Be sure to check all packing material carefully for small parts. Which may have come loose inside the carton during shipment. Identify and count all parts and compare with the hardware list as below:

	No.	Picture	Description	Dimension	Qty
Hardware list	①		JCBC (M6) with washer	6 x P1.0 x 40mm	2 Pcs
	②		JCBC (M6) with washer	6 x P1.0 x 60mm	4 Pcs
	③		JCBC (M6) with washer	6 x P1.0 x 80mm	4 Pcs
	④		Allen Wrench (M4)	4 x 110mm	1 Pc
Parts list	No.	Description			Qty
	A	Back Rest			1 Pc
	B	Front Leg (L & R)			2 Pcs
	C	Cushion Seat with Seat Frame			1 Pc

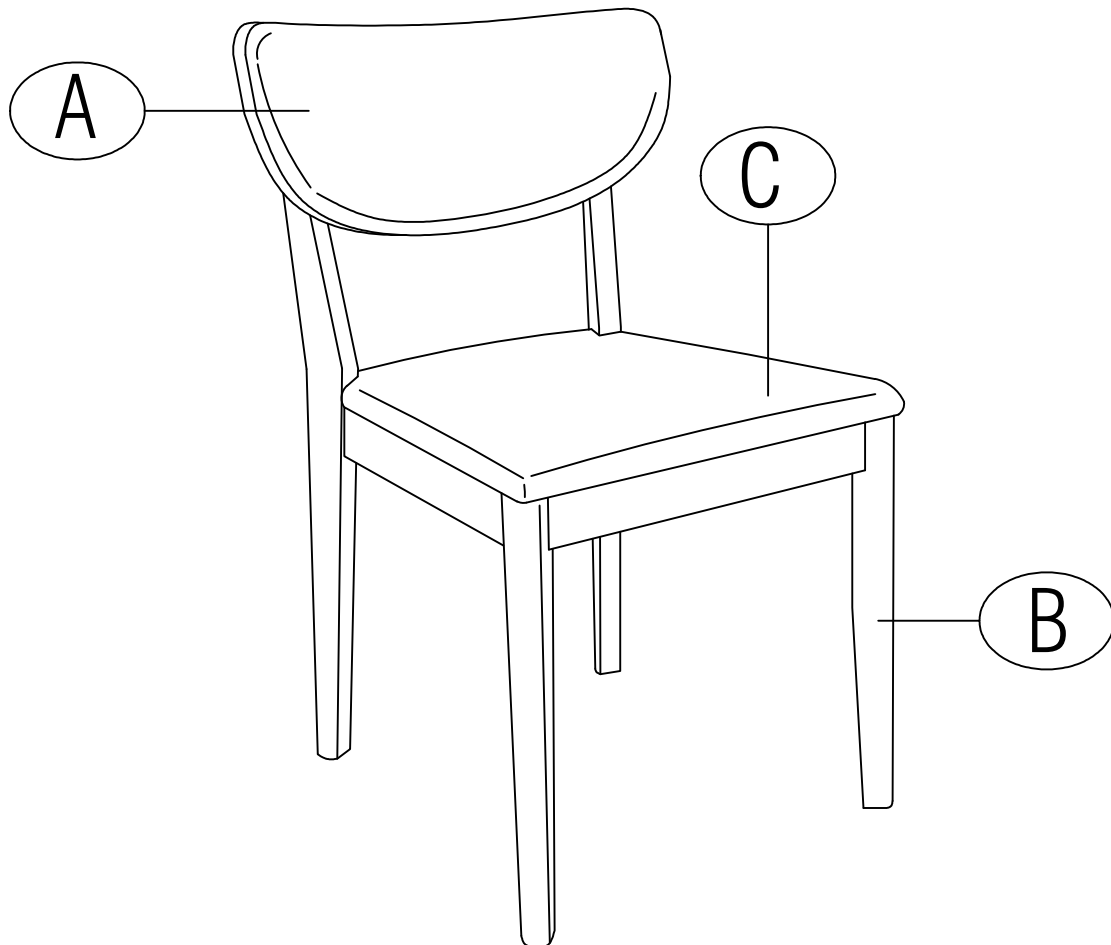

PARTS DETAILS

Assembly step

STEP 1

Assemble seat frame to the backrest (NOTE : USE HARDWARE IN LABEL 1)

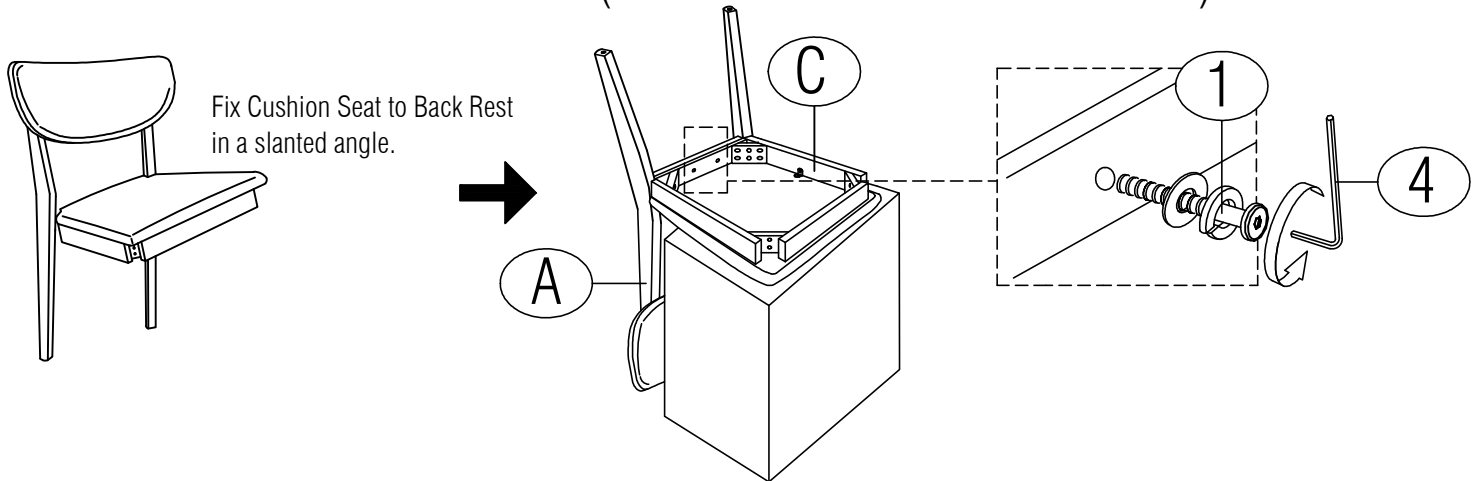

STEP 2

Assemble seat frame backrest (NOTE : USE HARDWARE IN LABEL 3)

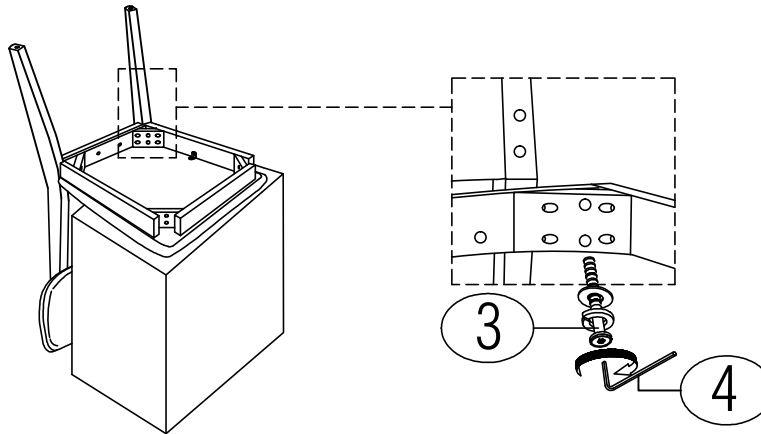

STEP 3

Assemble front legs to the seat frame (NOTE : USE HARDWARE IN LABEL 2)

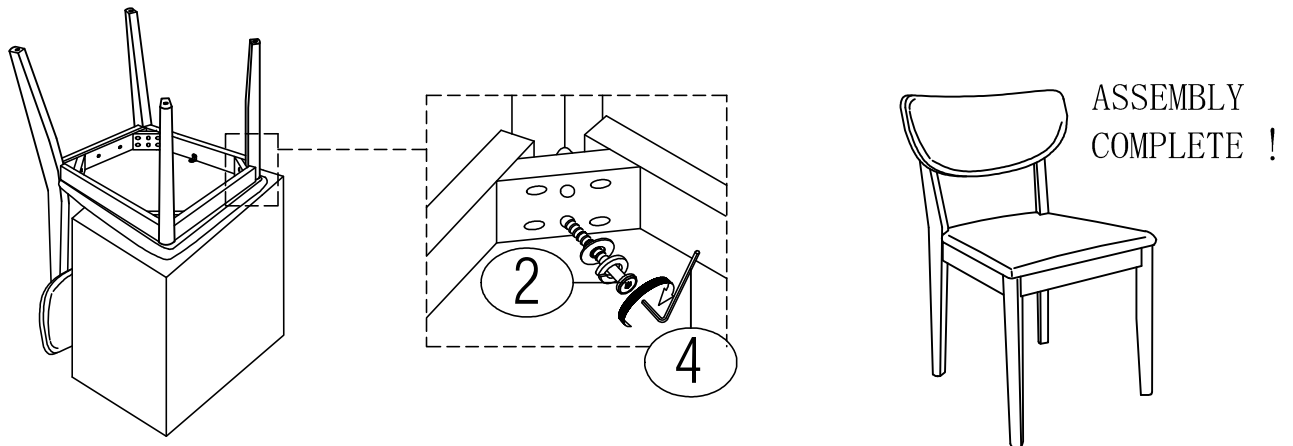

NOTE :

To ensure that chair is level, assemble the chair on flat & sort surface. DO NOT tighten all the screws & bolts until the chair been adjust & level all the legs so that they do not wobble. Once adjusted then only tighten all the screws using Allen Key while making sure that the unit remain level.