

Assembly Instruction

Instructions d'assemblage











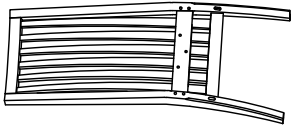

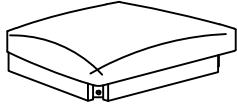
STOF

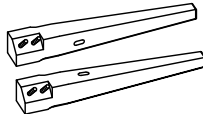
8048-561S

SLAT BACK SIDE CHAIR

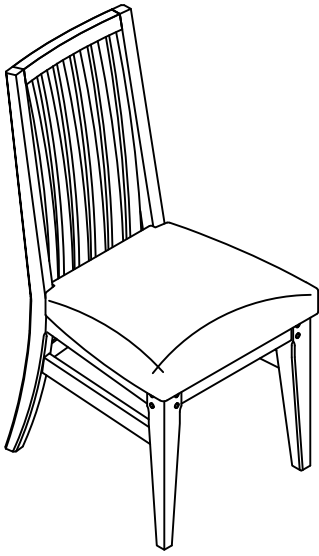
SKU# 42480486

WARNING: To avoid alignment issue, please don't tighten the screws unless all legs are adjusted at the same level.

HARDWARE LIST / LISTE DE QUINCAILLERIE		QTY' / QTÉ	PART LIST/LISTE DE PIÈCES		QTY' / QTÉ		
A	Hex-Nut Ø5/16"		4 pcs 4 pièces	1	CHAIR BACK DOSSIER DE CHAISE		1 PC 1 PIÈCE
	Ecrou Hexagonal Ø5/16"						
B	Short Bolt φ1/4" x 20 x 1-1/2"		3 pcs 3 pièces	2	SEAT SIEGE		1 PC 1 PIÈCE
	Boulon Ø1/4" x 20 x 1-1/2"						
C	Long Bolt φ1/4" x 20 x 3-1/2"		4 pcs 4 pièces	3	FRONT LEG (LEFT - RIGHT) PIEDS AVANT (GAUCHE - DROIT)		2 PCS 2 PIÈCES
	Boulon Ø1/4" x 20 x 3-1/2"						
D	Spring Washer Ø5/16" x Ø1/2" x 1/16"		11 pcs 11 pièces	4	SIDE STRETCHER (LEFT - RIGHT) BARREAU (GAUCHE - DROIT)		2 PCS 2 PIÈCES
	Rondelle de ressort Ø5/16" x Ø1/2" x 1/16"						
E	Flat Washer Ø5/16" x Ø3/4" x 1/16"		11 pcs 11 pièces				
	Rondelle plate Ø5/16" x Ø3/4" x 1/16"						
F	Wrench 3" x 1/2"		1 pc 1 pièce				
	Clé 3" x 1/2"						
G	Allen Key 5/32"		1 pc 1 pièce				
	Clé Allen 5/32"						
H	Screw Ø8 x Ø4 x 2"		4 pc 4 pièces				
	Vis a bois Ø8 x Ø4 x 2"						

TOOLS REQUIRED (NOT PROVIDED)

Phillips Screwdriver



Hardware Pack Location(s):

STOF

8048-561S

SLAT BACK SIDE CHAIR

SKU# 42480486

Assembly Instruction Instructions d'assemblage

STOF

8048-561S

SLAT BACK SIDE CHAIR

SKU# 42480486

***Caution: Please read all instructions carefully before starting the assembly process. These parts are cumbersome and heavy. Therefore, two people are recommended in order to prevent personal injury and ensure the parts are not damaged during the assembly.

***Avertissement: veuillez lire toutes les instructions attentivement avant de commencer l'assemblage. Ces pièces sont encombrantes et lourdes. Il est recommandé d'être deux personnes pour l'assemblage afin de prévenir des blessures et/ou risquer d'endommager les pièces.

STEP 1 ÉTAPE 1

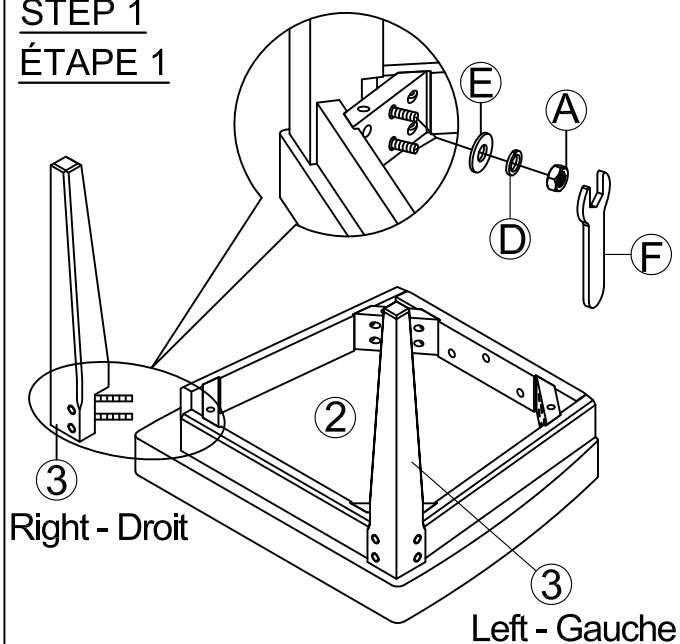

Attach the front legs to the seat frame.

Note: Do not tighten all screws & bolts until the seat is fully assembly

STEP 2 ÉTAPE 2

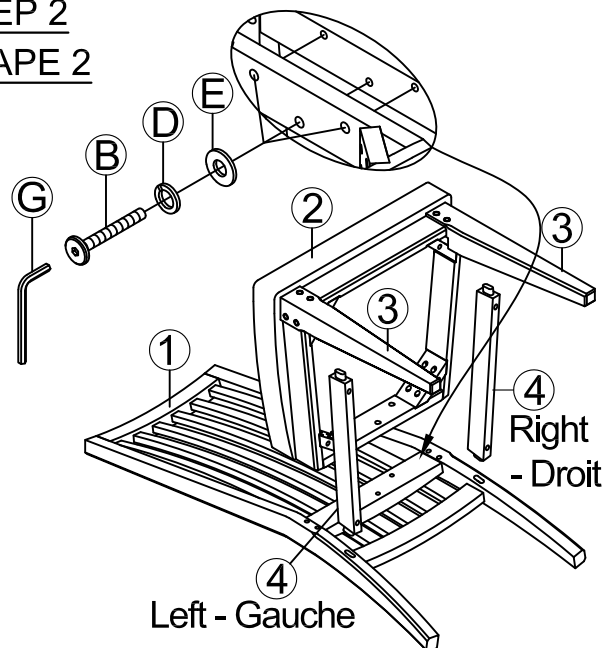

Attach the seat frame & front legs, side stretcher to the chair back.

STEP 3 ÉTAPE 3

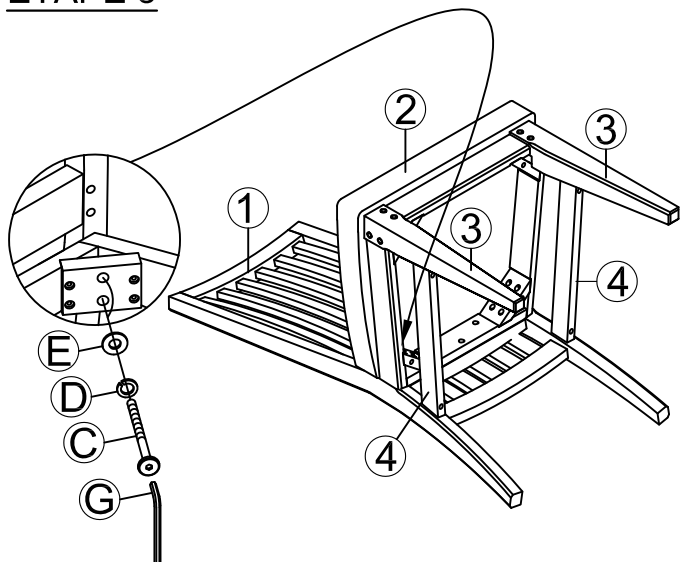

Screw the seat frame corner to the rear legs.

STEP 4 ÉTAPE 4

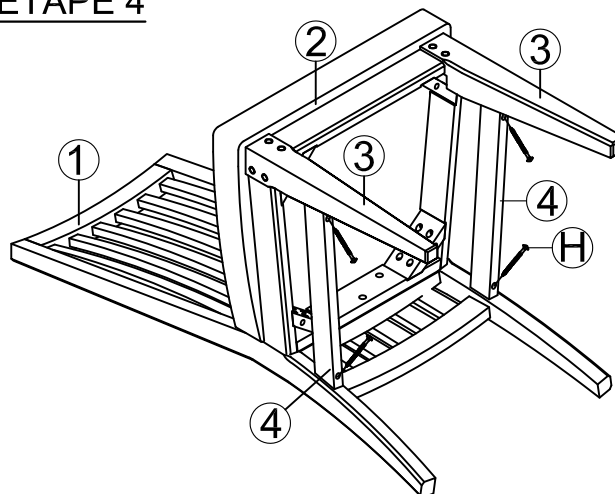

Attach the screw into the side stretchers