

Assembly Instructions





HFVC 8470/8471-4 UPHOLSTERED SIDE CHAIR

SKU# 42484701/42484713





This product is manufactured by HFVC for

ROOMS TO GO

*****Caution:** Please read all instructions carefully before starting the assembly process. These part are cumbersome and heavy. Therefore, two people are recommended in order to prevent personal injury and ensure the parts are not damaged during the assembly.

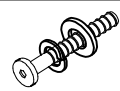
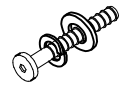
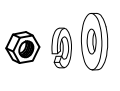
Code	PART LIST		
1	Chair Back		1PC
2	Seat Frame with Cushion		1PC
3	Front Leg Right		1PC
4	Front Leg Left		1PC
5	Side Stretcher		2PCS

TOOLS REQUIRED (NOT PROVIDED)	
Description	Sketch
Phillips Screwdriver	

Step	Code	HARDWARE LIST		
1-2	A	Allen bolt Ø5/16**18*80mm		4pcs
		Lock washer Ø5/16**13*2mm		4pcs
		Flat washer Ø5/16**19*2mm		4pcs
1-2-3-4	B	Allen bolt Ø1/4**20*45mm		2pcs
		Lock washer Ø1/4**11*mm		2pcs
		Flat washer Ø1/4**19*2mm		2pcs
1-2-3-4	C	Hex nut Ø5/16**12*6mm		4pcs
		Lock washer Ø5/16**13*2mm		4pcs
		Flat washer Ø5/16**19*2mm		4pcs
	D	Open wrench M12*L90mm		1pc
	E	4mm Allen key		1pc
	F	Wood screw #10*38mm		4pcs

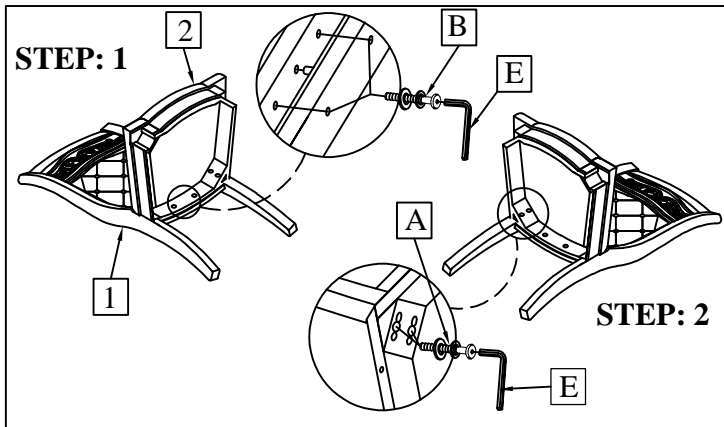

Assemble the cushion seat bar with the chair back.
Do not tighten all bolts until seat cushion is fully assembly

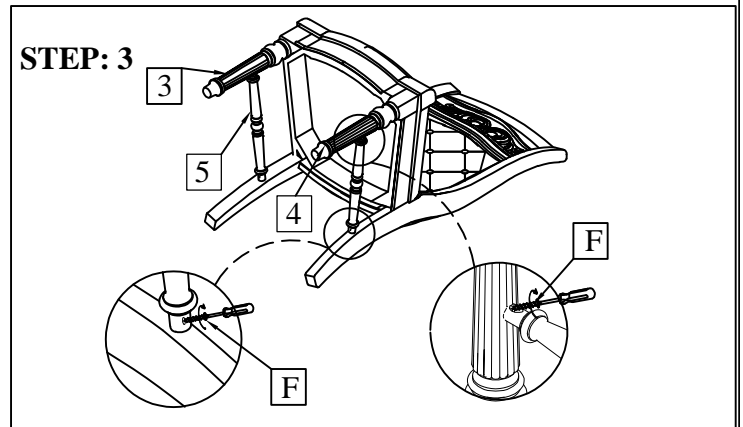

Assemble the cushion seat comer with the chair back.

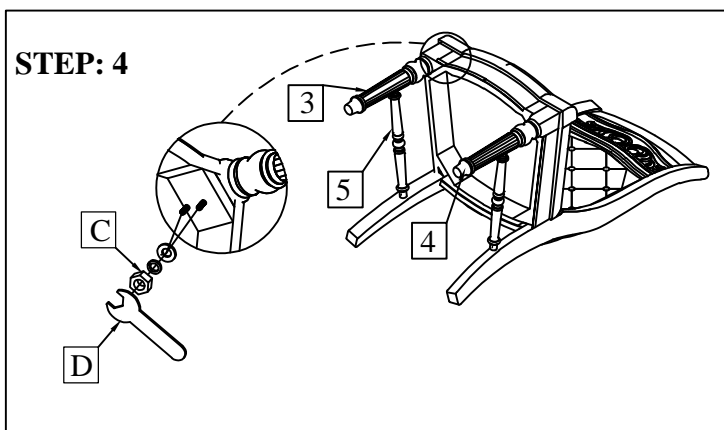

Secure the side stretcher to the chair back and front leg by putting the side stretchers in the correct like pictue show.
Do not tighten all bolts until seat cushion is fully assembly

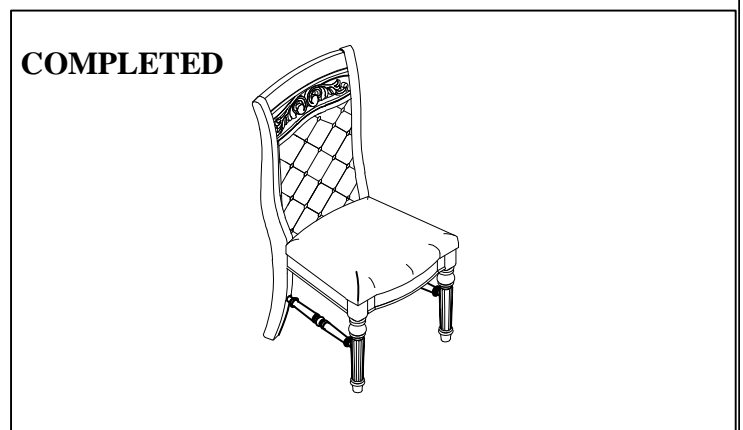

Hardware Pack location(s)

HFVC 8470/8471-4 UPHOLSTERED SIDE CHAIR SKU# 42484701/42484713

MADE IN VIETNAM

Residential Use Only

Version 1: 23-Feb-2024

1 OF 1