

Assembly Instructions





HMIS 3301-06 Arm Chair



SKU# : 42633013

HMIS 3303-04 Side Chair

SKU# : 42633037

*****Caution:** Please read all instructions carefully before starting the assembly process. These parts are cumbersome and heavy. Therefore, two people are recommended in order to prevent personal injury and ensure the parts are not damaged during the assembly

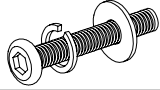
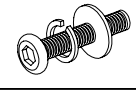
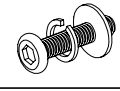
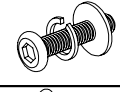
Code	PARTS LIST:		
1	Chair Back		1Pc
2	Cushion Seat		1Pc
3	Front Legs		2Pcs
4	Left Arm		1Pc
5	Right Arm		1Pc

Step	Code	Hardware List		
2	A	Bolt - Ø5/16x18x90mm		4Pcs
		Flat washer - Ø5/16x22x1.5mm		4Pcs
		Lock washer - Ø5/16		4Pcs
1	B	Bolt - Ø5/16x18x58mm		4Pcs
		Flat washer - Ø5/16x22x1.5mm		4Pcs
		Lock washer - Ø5/16		4Pcs
3	C	Bolt - Ø5/16x18x38mm		2Pcs
		Flat washer - Ø5/16x22x1.5mm		2Pcs
		Lock washer - Ø5/16		2Pcs
4	D	Bolt - Ø1/4x20x38mm		4Pcs
		Flat washer - Ø1/4x19x1.5mm		4Pcs
		Lock washer - Ø1/4		4Pcs
5	E	Bolt - Ø1/4x20x38mm		2Pcs
1-2-3 4-5	F	Allen Key - 4mm		1Pc

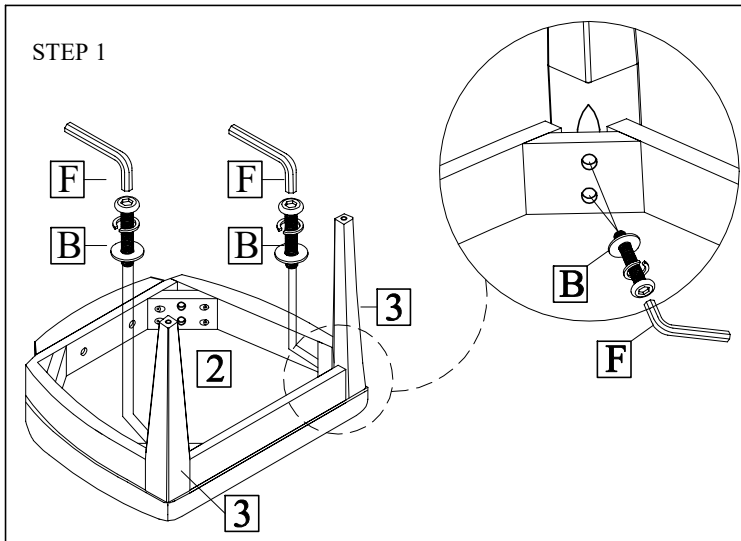

Assemble Front Legs(3) with Cushion Seat(2) using flat washers(B)+ lock washers(B) and bolts(B) by allen key (F).
Do not tighten all bolts until Chair is fully assembly.

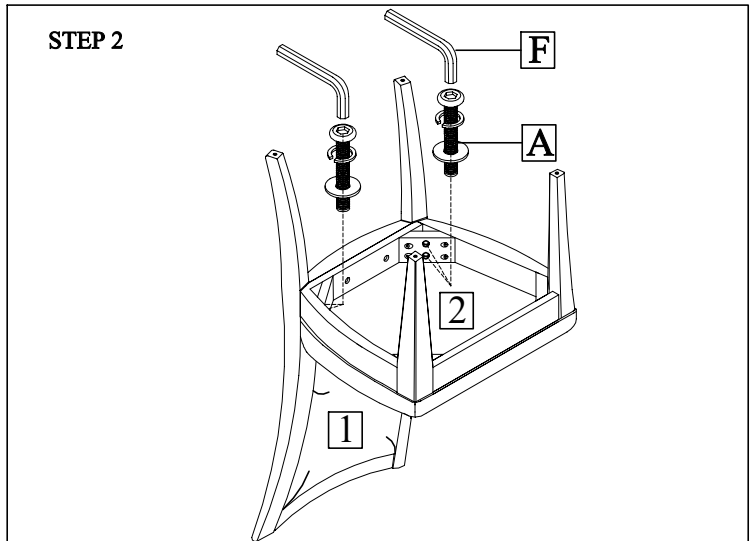

Assemble Cushion Seat(2) with Chair Back(1) using flat washers(A) + lock washers(A) and bolts(A) by allen key (F).
Do not tighten all bolts until Chair is fully assembly.

STEP 3

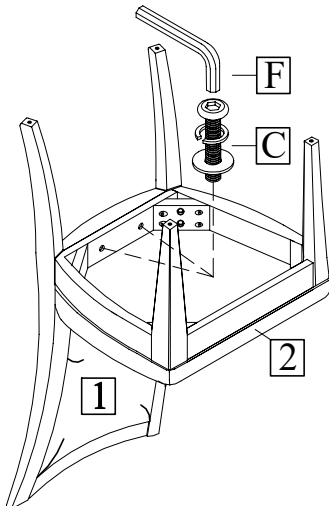

Assemble Cushion Seat(2) with Chair Back(1) using flat washers(C)+ lock washers(C) and bolts(C) by allen key (F).
Do not tighten all bolts until Chair is fully assembly.

Hardware Pack Location(s):
Arm Chair, SKU# : 42633013
Arm Chair, SKU# : 42633037

This product is manufactured by HMIS for

ROOMS TO GO ►

Assembly Instructions

HMIS 3301-06 Arm Chair
HMIS 3303-04 Side Chair

SKU# : 42633013
SKU# : 42633037

***Caution: Please read all instructions carefully before starting the assembly process. These parts are cumbersome and heavy. Therefore, two people are recommended in order to prevent personal injury and ensure the parts are not damaged during the assembly

STEP 4

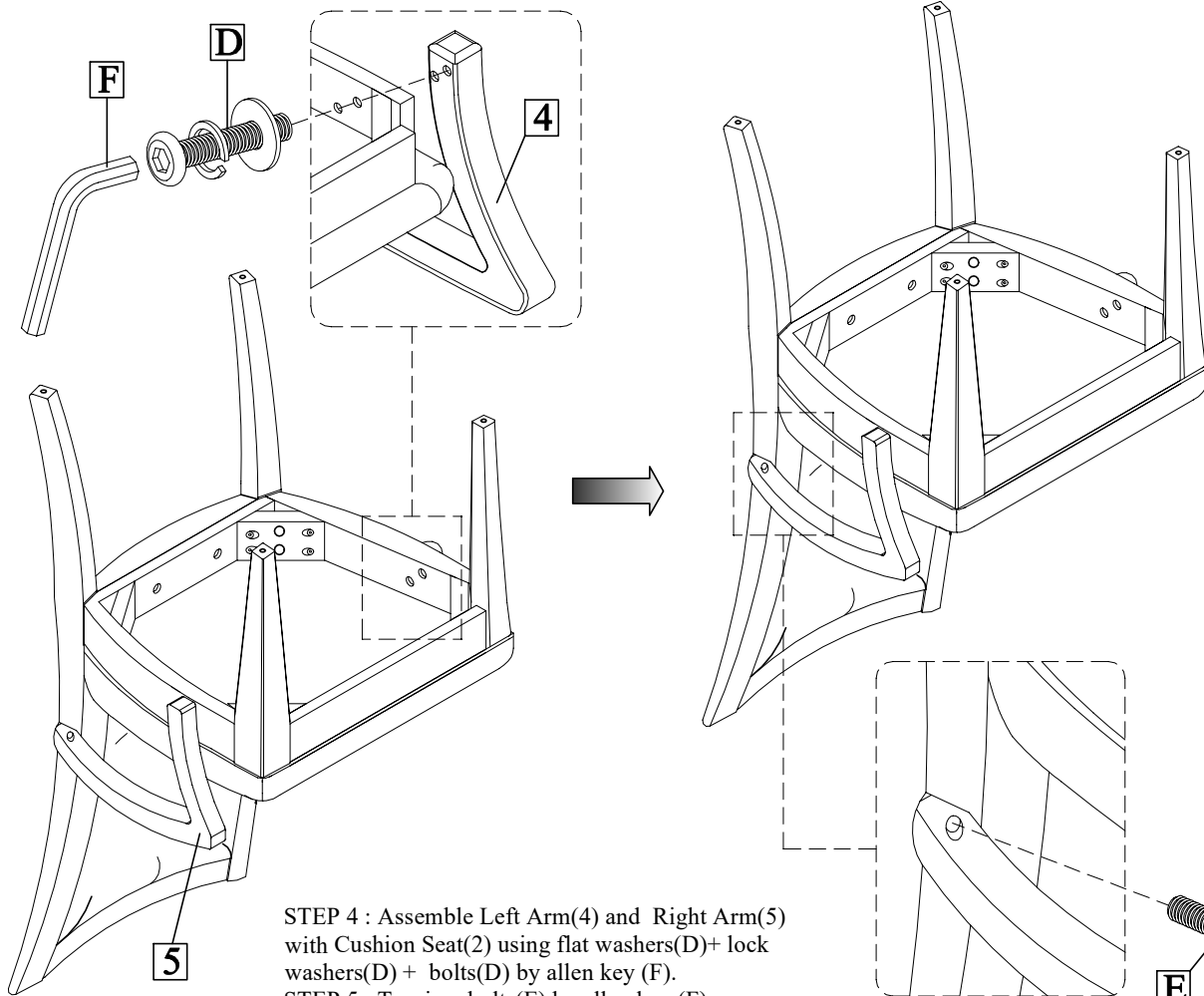

STEP 4 : Assemble Left Arm(4) and Right Arm(5) with Cushion Seat(2) using flat washers(D)+ lock washers(D) + bolts(D) by allen key (F).
STEP 5 : Turning bolts(E) by allen key (F). Fully tighten all bolts at this step.

STEP 5

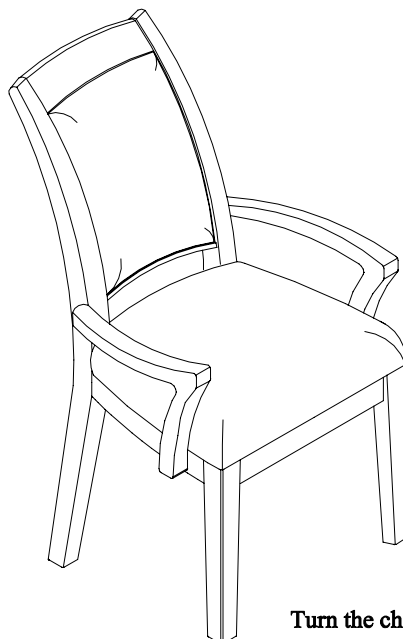
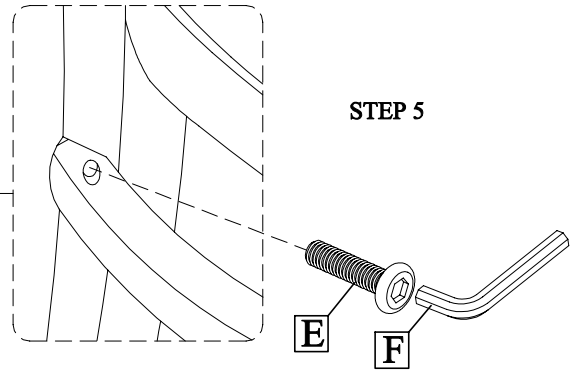

Turn the chair to upright position carefully.

This product is manufactured by HMIS for

ROOMS TO GO ►