



ASSEMBLY INSTRUCTIONS



MODEL : 2640KM

STOF

7217-SCG SIDE CHAIR, GRAY (FELIX FABRIC) (SKU#42472174)

7217-SCB SIDE CHAIR, BLUE (TALENT FABRIC) (SKU#42672178)

Thank you for purchasing this quality product. Be sure to check all packing material carefully for small parts. Which may have come loose inside the carton during shipment. Identify and count all parts and compare with the hardware list as below :

| | No. | Picture | Description | Dimension | Qty |
|---------------|-----|---|--------------|------------------------|-------|
| Hardware List | ① |  | JCBC M6 | 6 X P1.0 X 50 [Length] | 4 PCS |
| | ② |  | ALLEN WRENCH | M4 | 1 PC |
| Part List | No. | Description | | | Qty |
| | A | SEAT | | | 1 PC |
| | B | LEG | | | 1 PC |

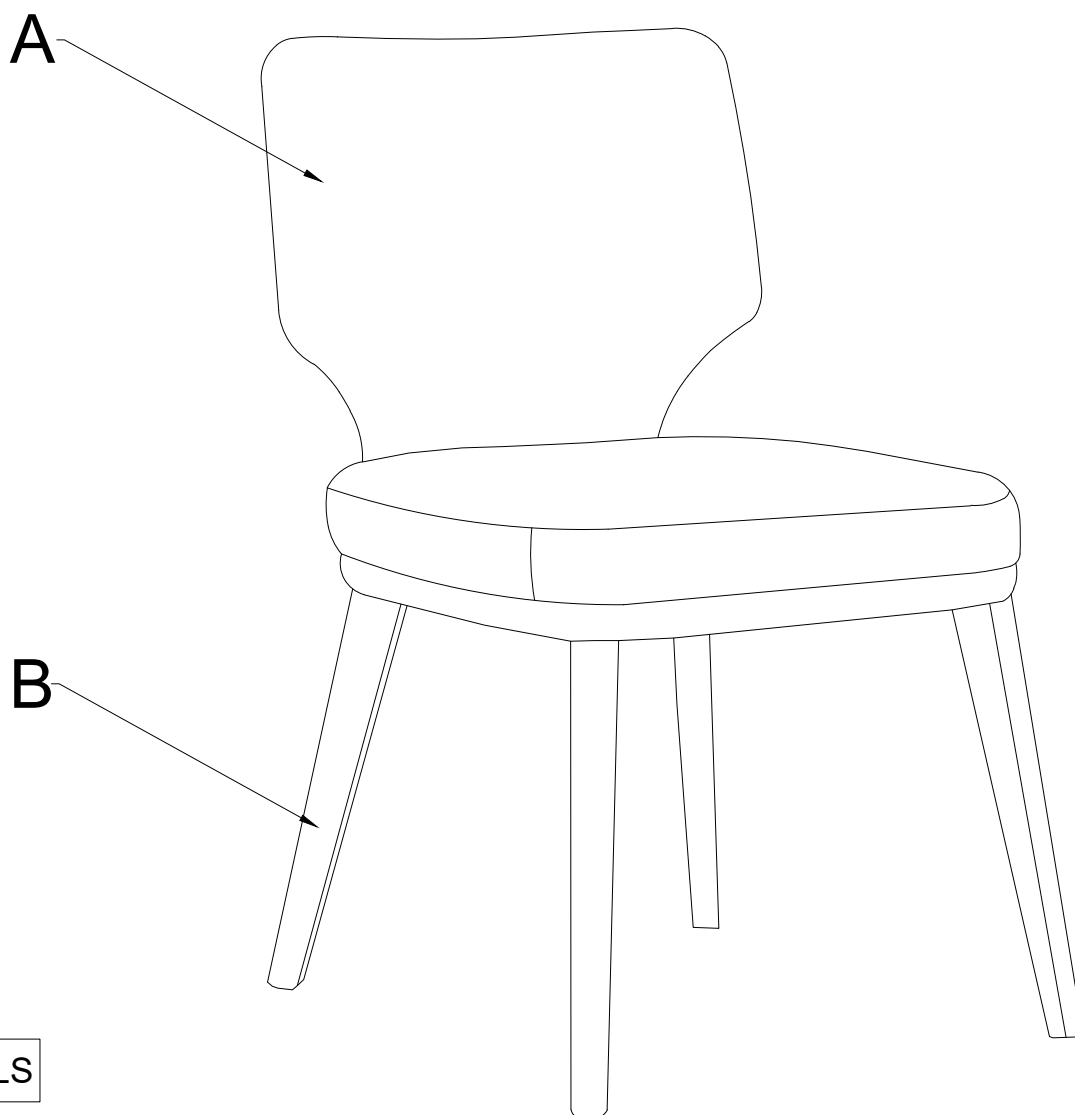

PARTS DETAILS

Assembly step

STEP 1

Assemble the leg to the SEAT together as illustration shown.
TIGHTEN THE SCREWS UNTIL 70%.

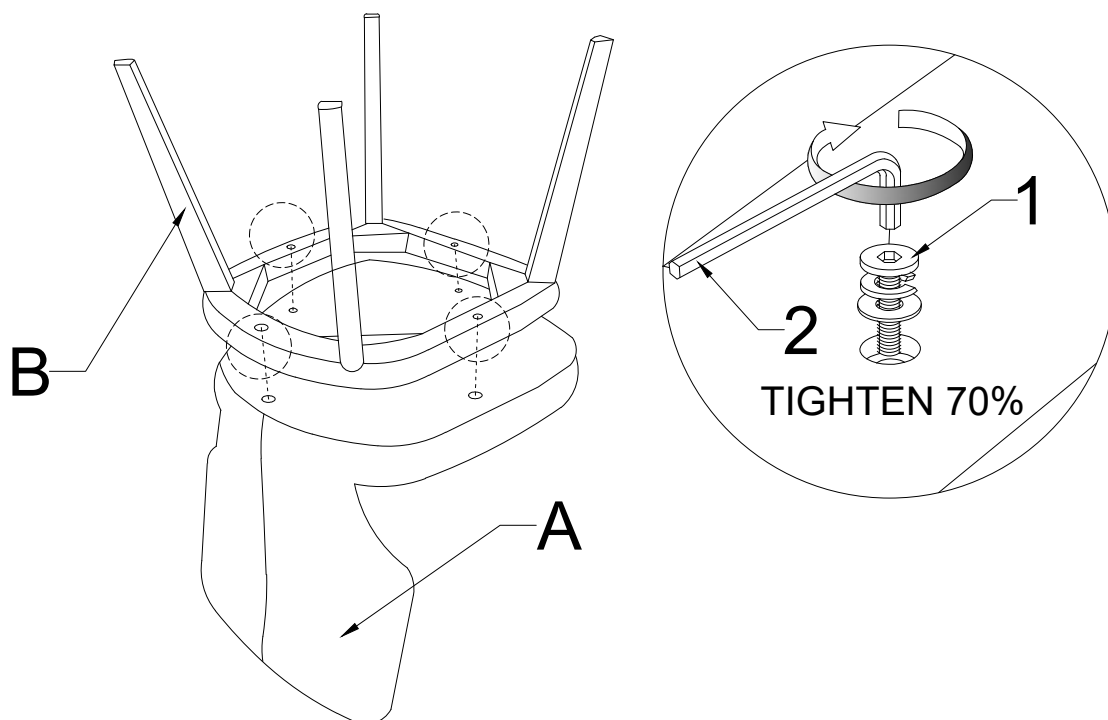

STEP 2

TIGHTEN THE SCREWS UNTIL 100%.

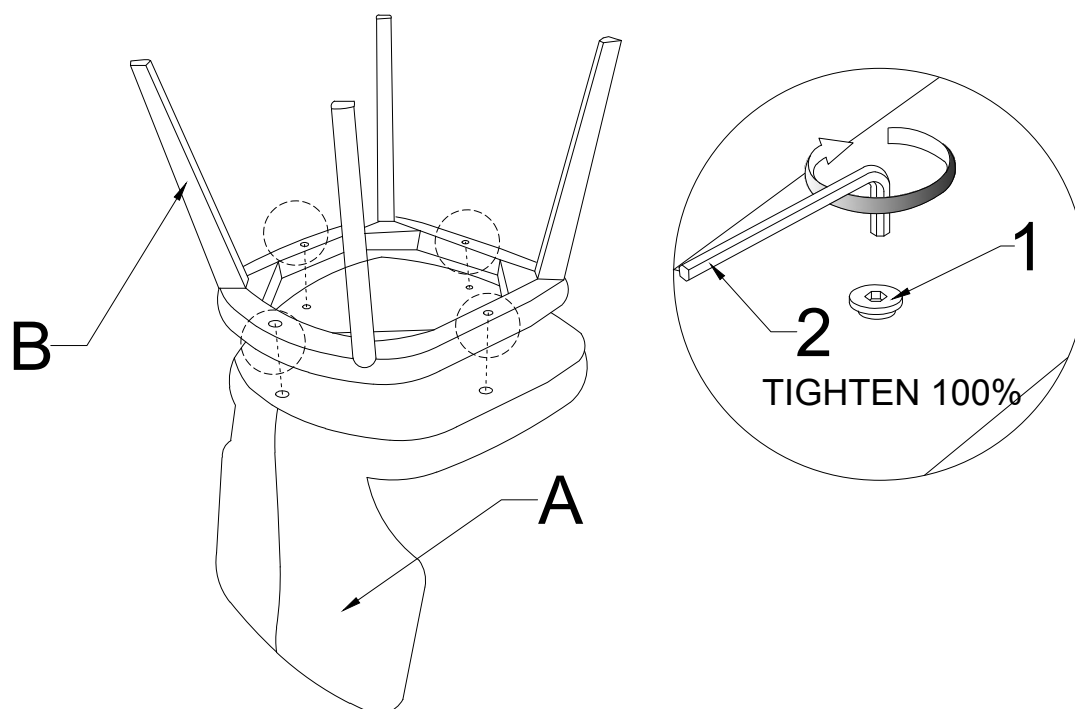

NOTE :

To ensure that chair is level , assemble the chair on flat & soft surface. DO NOT tighten all the screw & bolts until the chair been adjust & level all the legs so that they do not wobble. Once adjusted then only tighten all the screw using Allen Key while making sure that the unit remain level.