

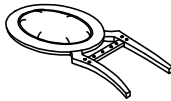









# Assembly Instructions for NAJA CAPRI OVAL SIDE CHAIR

Thank you for purchasing this quality product. Be sure to check all packing material carefully for small parts, which may have come loose inside the carton during shipment. Identify and count all parts and compare with the **HARDWARE LIST** below.

Caution : Please read instructions thoroughly before unpacking assembly parts.

1. We recommend that you should assemble this product with the assistance of another person; this will make assembly easier, and will help to eliminate damage to the product or injury to persons during assembly.
2. Please do not over tighten screws or bolts until the assembly is completed.
3. Please put all parts on a non - abrasive floor before assembly, and follow the assembly steps to assemble your newly purchased product correctly and efficiently.
4. All hardware pack number are the same as Assemble step number.

NO.	PARTS LIST	Q'TY	NO.	HARDWARE PACK	Q'TY
A	Chair Back 	1	1	 Ø5/16"x18 x 3"L Allen bolt	6
				 Ø5/16"xØ13mmx1.2mmT Spring washer	
			 Ø5/16"x19x2mmT Flat washer		
B	Seat Cushion 	1		 Allen Key ( 4mm )	1
C	Front Legs 	2	2	 Ø5/16" x 6mm hex nut	4
				 Ø5/16"xØ13mmx1.2mmT Spring washer	
			 Ø5/16"x19x1.8mmT Flat washer		
				 Open wrench 12mm	1

**STEP: 1**

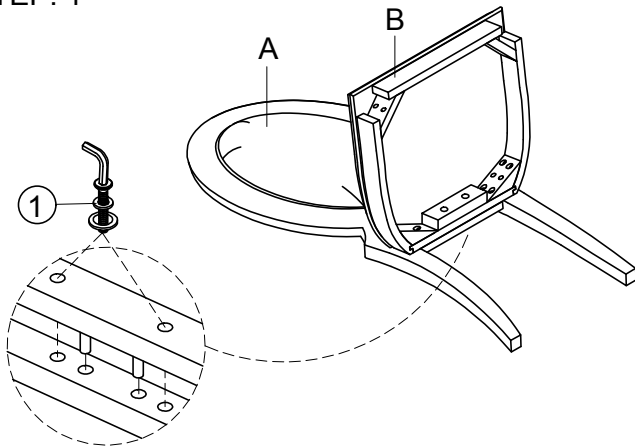

**STEP: 2**

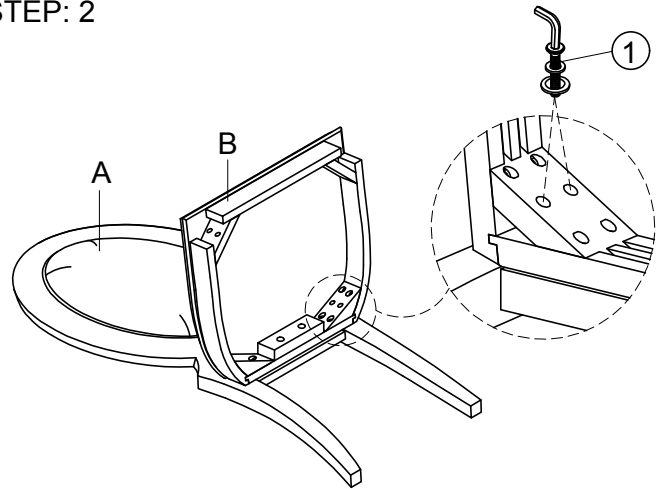

**STEP: 3**

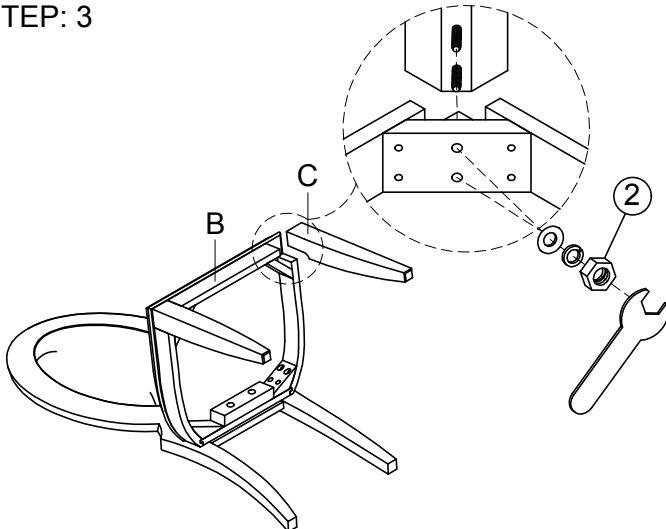

**Assembly Completed**

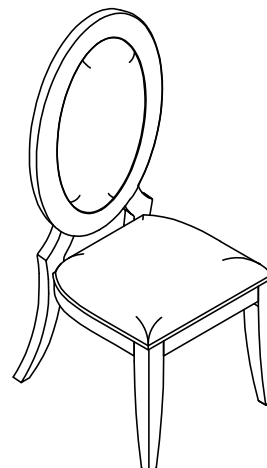

MADE IN VIETNAM