



# ASSEMBLY INSTRUCTIONS

SSIO SKU#: 5518-9

SKU#: 42955180

WALDORF SERVER



WALDORF SERVER

5518-9

5518-9

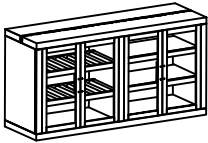
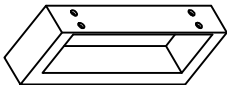
\*\*\* Caution. Please read all instructions carefully before starting the assembly process. These parts are cumbersome and heavy. Therefore, two people are recommended in order to prevent personal injury and insure the parts are not damaged during the assembly.

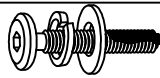
No.	PARTS LIST		
A		Server	1
B		Metal Leg	2

No.	HARDWARE LIST		
1		Allen Bolt $\Phi \frac{1}{4}'' \times 25$ mm (20 TPI)	8
		Lock Washer $\Phi \frac{5}{16}'' \times 13$ mm	8
		Flat Washer $\Phi \frac{5}{16}'' \times 19$ mm	8
2		Allen Key 4 mm	1
3		Tipping Restraint	1 set

## Step 1

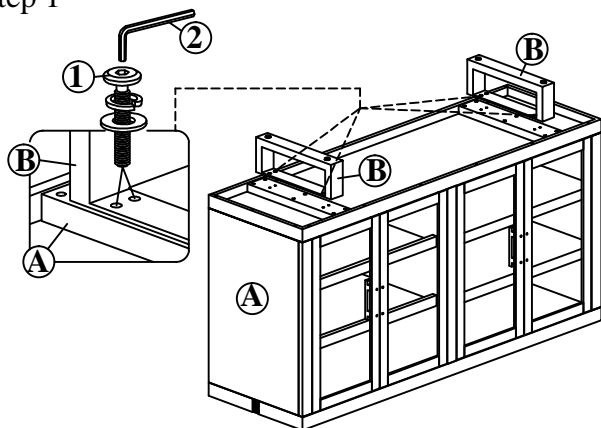

Place the Server (A) upside down on a piece of cloth or carpet to prevent the finish from scratching. Attach the Metal Leg (B) by using Bolt/ Lock Washer/ Flat Washer (1) and fully tighten with Allen Key (2) provided.

## Step 2

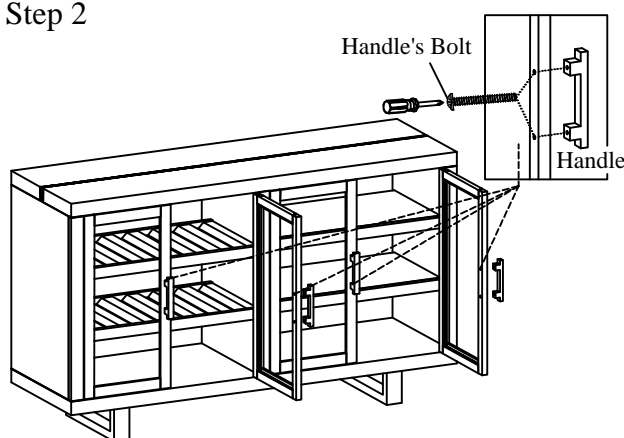

Turn the Server to the upright position. Open the door, attach the Handles from the inside to the outside of the door, and secure the Handle Bolts by a Phillips-head screwdriver (not provided).

## Step 3

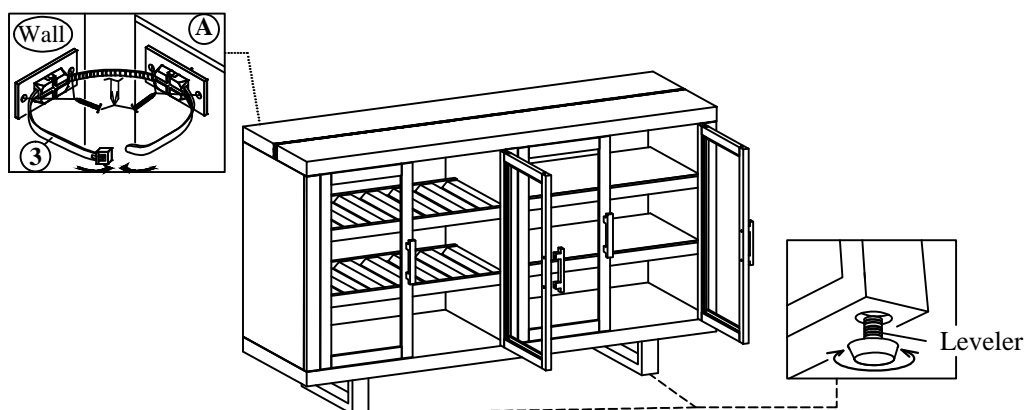

The Tipping Restraint (3) is stapled at the back of Server (A). Thread Tipping Restraint (3) through the Server's slots to fasten and lock as the picture shows. Adjust the Leveler so the Server is level and does not wobble. The server is assembly completed.

**CLEANING INSTRUCTION:** Clear with a soft cloth and warm water with a diluted mild detergent. Follow with a soft cloth and clear water rinse. Then dry thoroughly with a soft cloth.



MADE IN VIETNAM

SSIO

5518-9

WALDORF SERVER

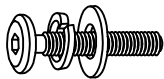
42955180

No.	Hardware List		QTY
1		Allen Bolt $\Phi \frac{1}{4}$ " x 25 mm (20 TPI)	8
		Lock Washer $\Phi \frac{5}{16}$ " x 13 mm	8
		Flat Washer $\Phi \frac{5}{16}$ " x 19 mm	8
2		Allen Key 4 mm	1

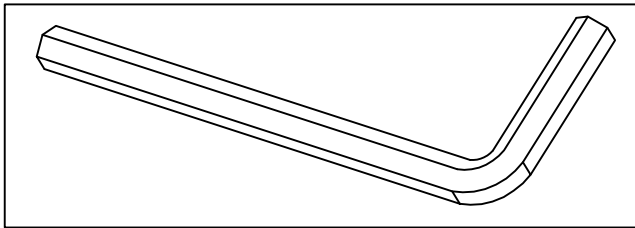

**2**

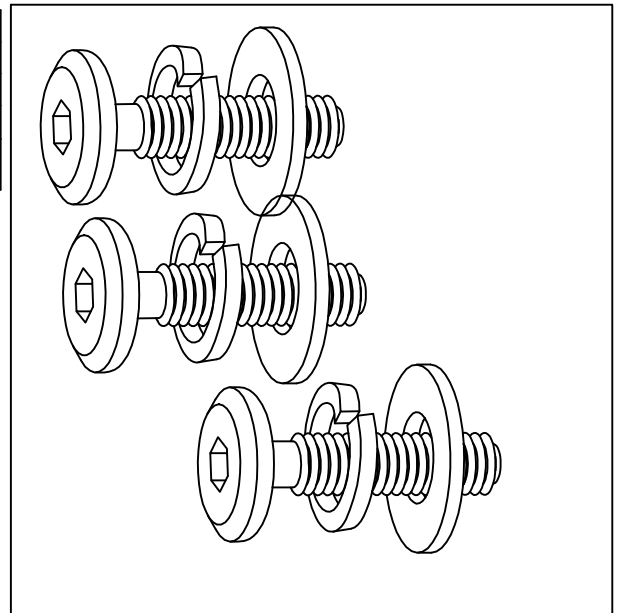

**1**