









Assembly Instructions

NAJA 9050-9 SERVER SKU # 42990502

Thank you for purchasing this quality product. Be sure to check all packing material carefully for small parts, which may have come loose inside the carton during shipment. Identify and count all parts and compare with the **HARDWARE LIST** below.

PARTS LIST	NO.	Description	Quantity	TOOLS REQUIRED (NOT PROVIDED)	
	A	SERVER	 1	Description	Sketch
	B	FRONT LEGS	 2	Phillips screwdriver	
	C	BACK LEGS	 2		

HARDWARE LIST	NO.	Description	Q' TY
	1	Hex nut 5/16"*12mm	 8
	2	Spring washer ϕ 5/16" * ϕ 13mm *1.5mm	 8
	3	Flat washer ϕ 5/16" * ϕ 19mm*1.5mm	 8
	4	Wrench 5/16"	 1
	5	Anti tipping kits	 1 Set

Remark:
Anti-tip hardware -
customer assembly required

STEP 2:

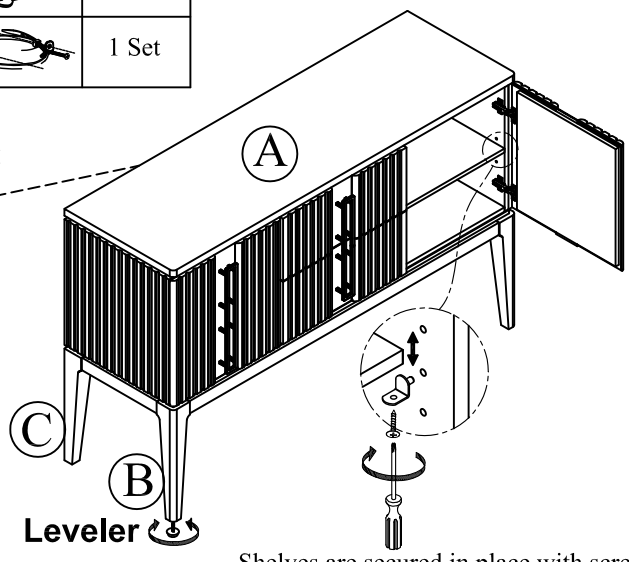
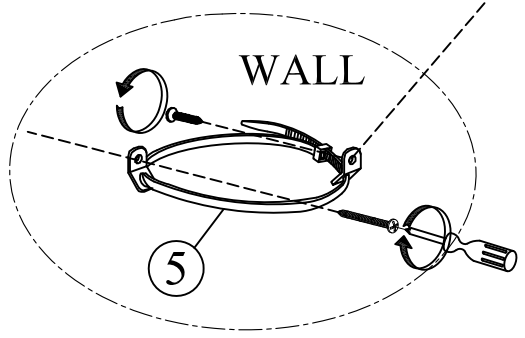

Shelves are secured in place with screws through a metal shelf pin for packing and shipping. In order to adjust the shelf remove the screw with philips head screwdriver (not included) and reposition to desired height.

STEP 1:

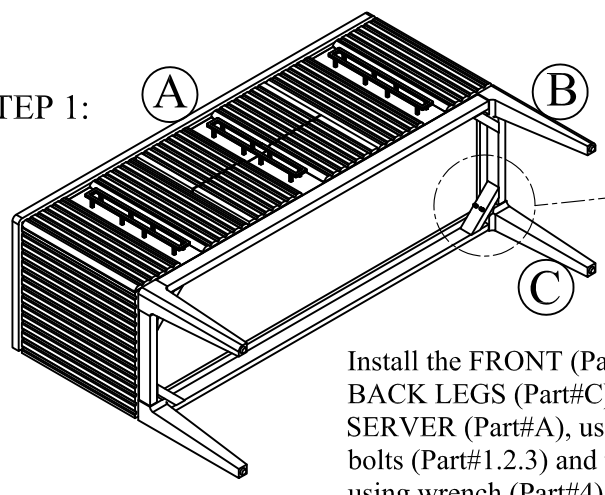

Install the FRONT (Part#B) and BACK LEGS (Part#C) onto the SERVER (Part#A), using the bolts (Part#1.2.3) and tighten using wrench (Part#4).

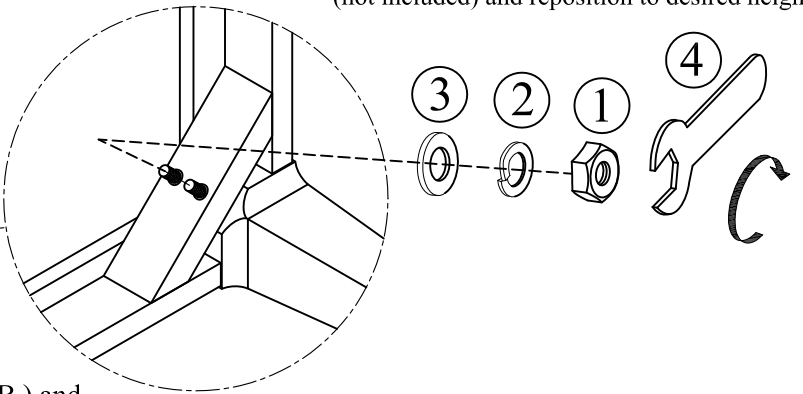

Hardware Pack Location(s)
NAJA 9050-9 SERVER

SKU # 42990502

This product is manufactured by NAJA for **ROOMS TO GO** ▶