

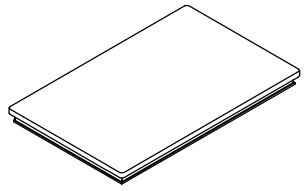

PARTS LIST

Step	Code	Hardware	Q'TY
	A	Allen Key 4 mm dia.	1 Pc
1	B	Allen Bolt 5/16" x 18 x 3"	8 Pcs
		Spring Washer 5/16" x 19 x 2mmT	
		Flat Washer 5/16" x 11 x 2mmT	
2	B	Allen Bolt 5/16" x 18 x 3"	4 Pcs
		Spring Washer 5/16" x 19 x 2mmT	
		Flat Washer 5/16" x 11 x 2mmT	
3	B	Allen Bolt 5/16" x 18 x 3"	4 Pcs
		Spring Washer 5/16" x 19 x 2mmT	
		Flat Washer 5/16" x 11 x 2mmT	



1. Table Top - 1 Pc



2. Shelf - 2 Pcs

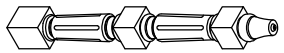

3. Table Leg - 4 Pcs

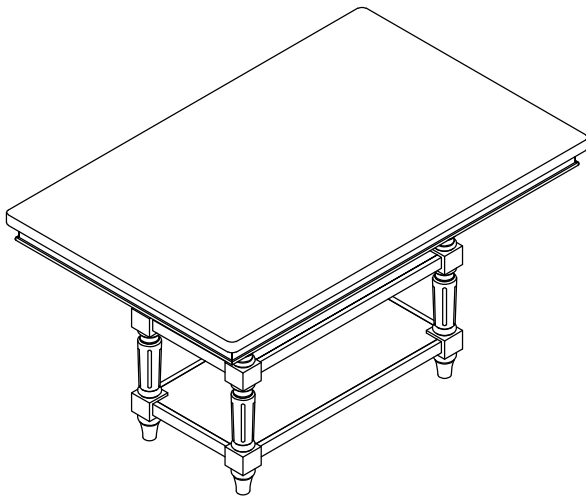

HARDWARE PACK LOCATION(S):

PNWD 2290-GT CNT HGT TABLE

SKU# 43222900

***Cautions: Please read all instructions carefully before starting the assembly process. These parts are cumbersome and heavy. Therefore, two people are recommended in order to prevent personal injury and insure the parts are not damaged during the assembly.

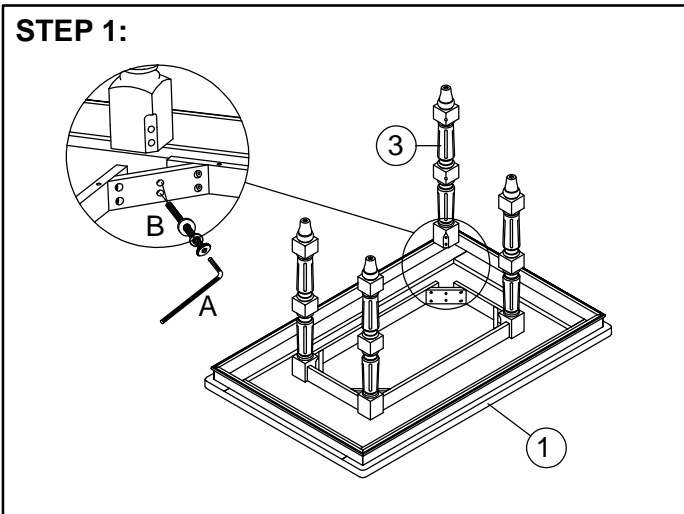
STEP 1:

Place the table top upside down. Attach the table legs to the table top.

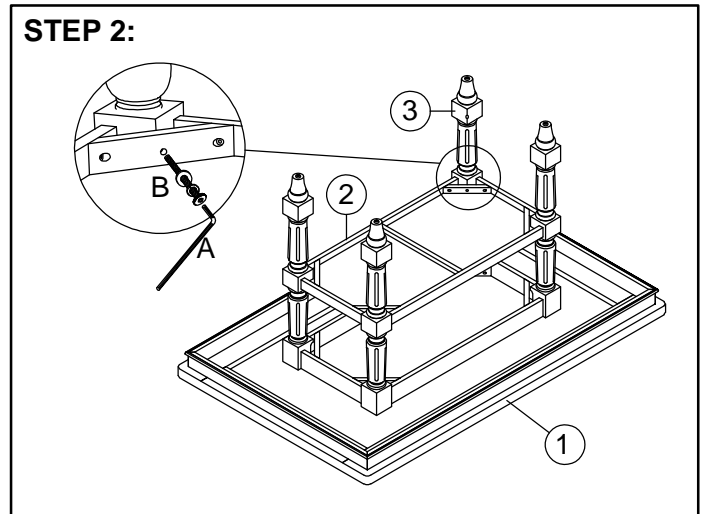
STEP 2:

Attach one shelf to the middle part of the table legs. Note: Do not tighten all bolts until the next step.

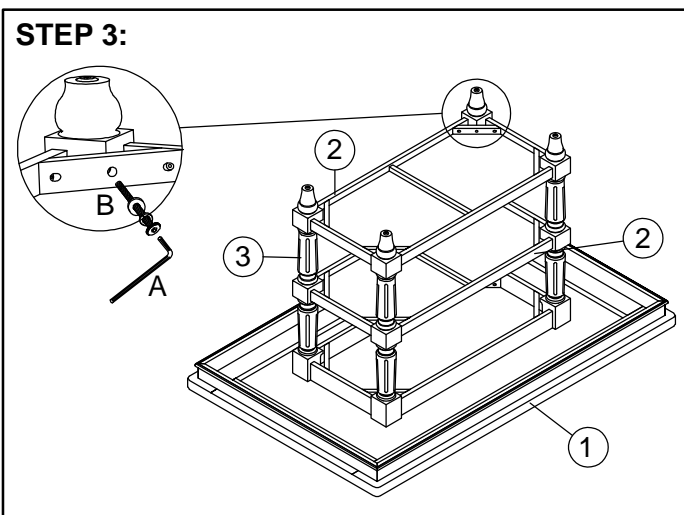
STEP 3:

Attach the other shelf to the lower part of the table legs.

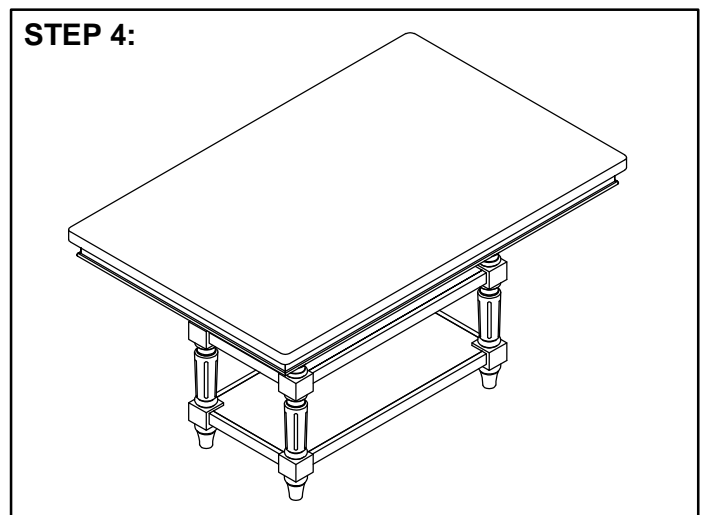
STEP 4:

Turn the table upright. Apply firm pressure to align and fully tighten all bolts.