







# ASSEMBLY INSTRUCTIONS

ITCO 4265- RCT ROUND COUNTER TABLE SKU# 43242659

Manufactured for Rooms To Go.

Thank you for purchasing this quality product. Be sure to check all packing material for small parts which may have come loose inside carton during shipment. Identify and count all parts and compare with the hardware list as below:

	No.	Picture	Description	Dimension	Qty
Hardware List	①		JCBC (M6) with washer	6 x P1.0 x 50mm	8 Pcs
	②		JCBC (M6) with washer	6 x P1.0 x 50mm	12 Pcs
	③		JCBC (M6) with washer	6 x P1.0 x 30mm	3 Pcs
	④		Allen Key	M4	1 Pc
Parts List	No.	Description			Qty
	A	Table Top			1 Pc
	B	Leaf Top			1 Pc
	C	Table Legs			1 Pc
	D	Bottom Rail- A			1 Pc
	E	Bottom Rail- B			1 Pc
	F	Top Rail- A			1 Pc
	G	Top Rail- B			1 Pc
H	Mounting Plate			1 Pc	

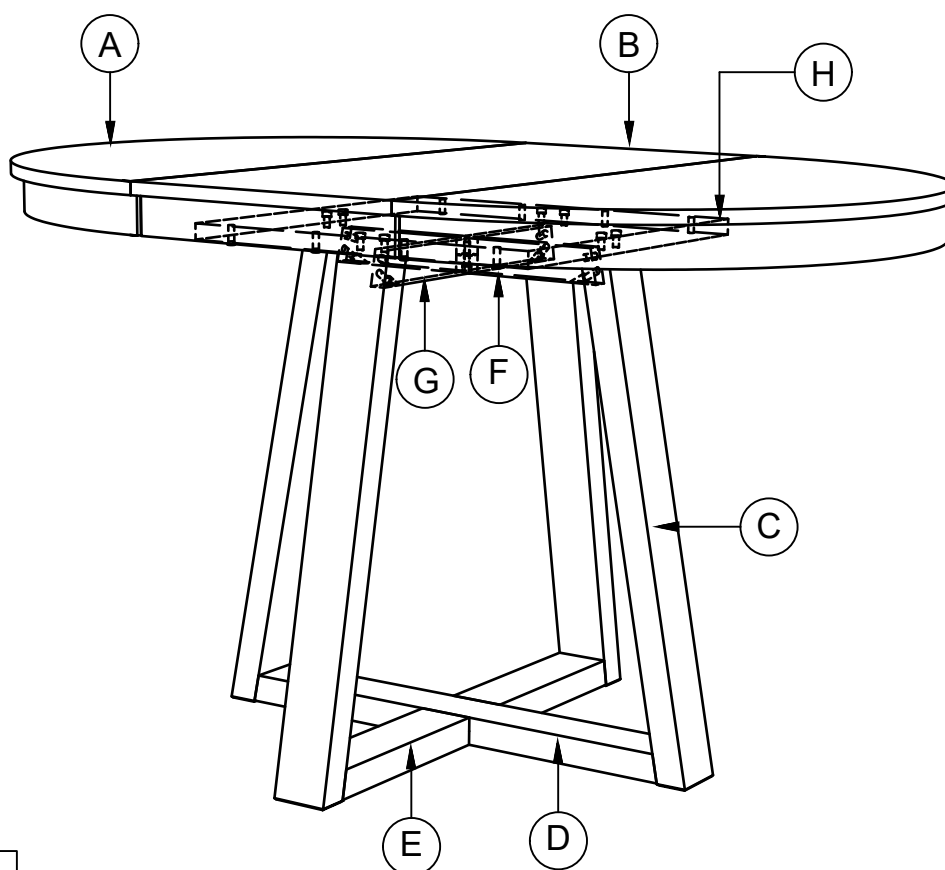

PARTS DETAIL

## Assembly steps

### STEP 1

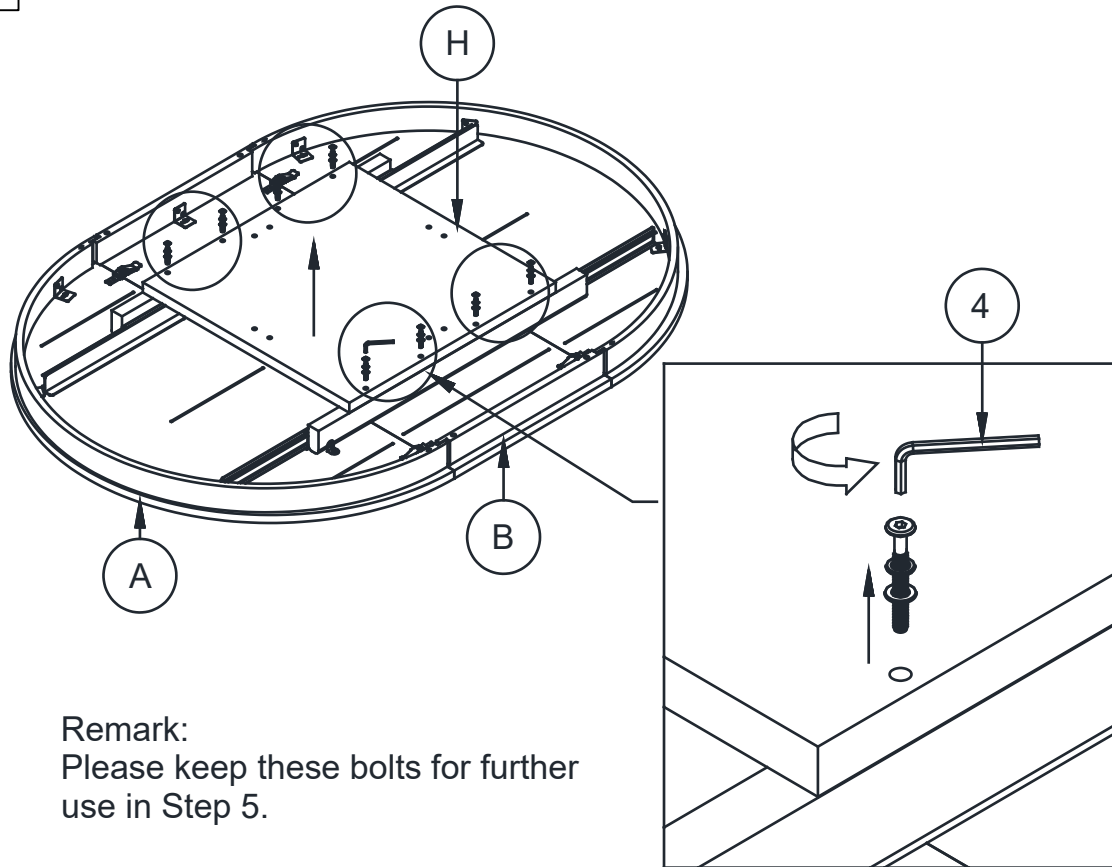

Remark:  
Please keep these bolts for further use in Step 5.

### STEP 2

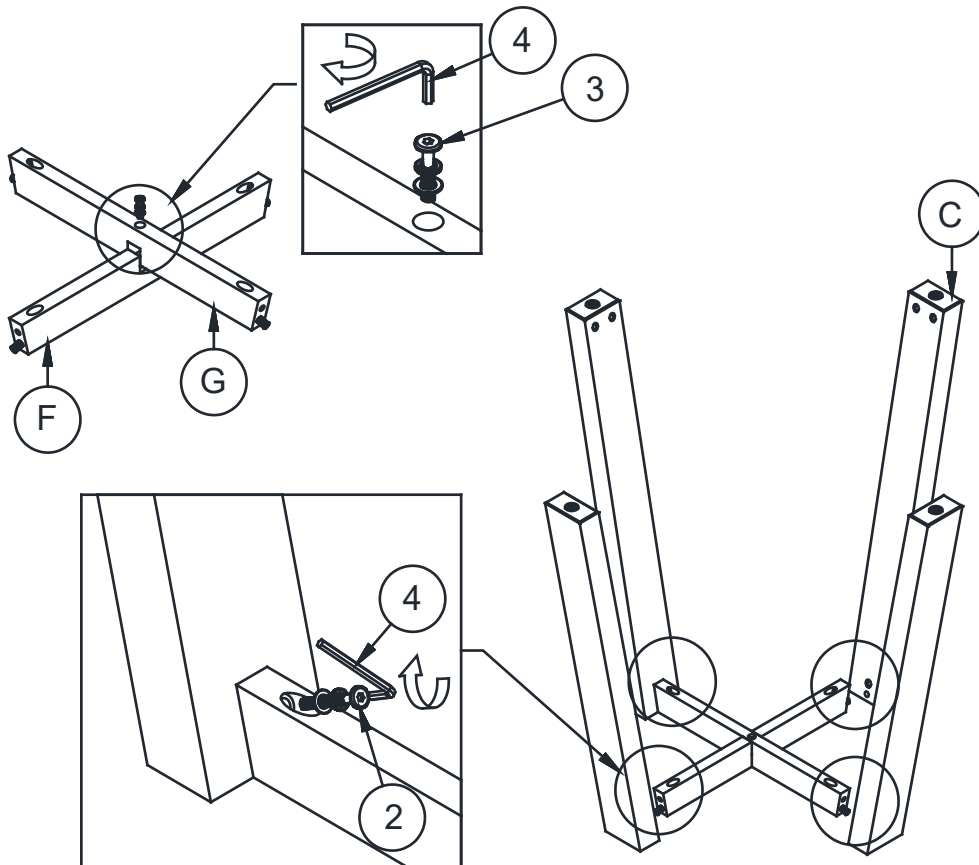

### NOTE :

Make sure this product assemble on the flat and soft surface. Follow the instructions. Tighten all the nuts, bolts or screws firmly and make sure this product does not wobble before use.

### Assembly steps

#### STEP 3

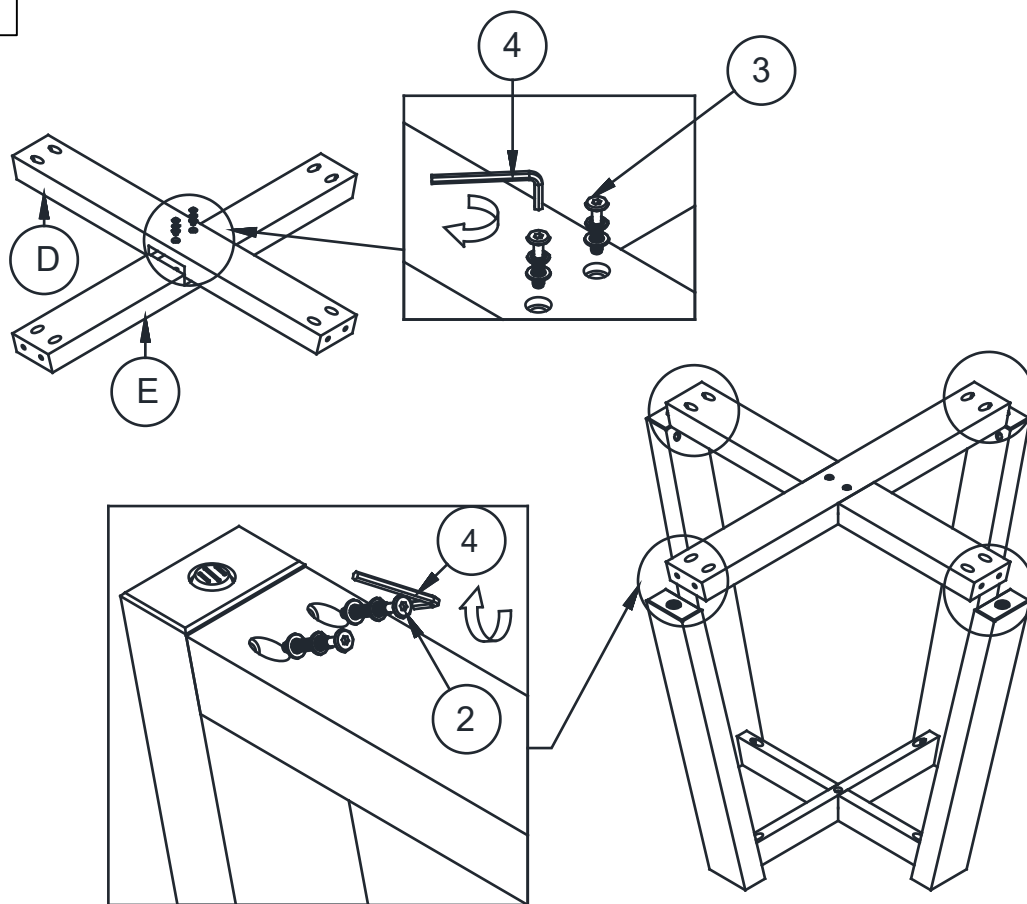

#### STEP 4

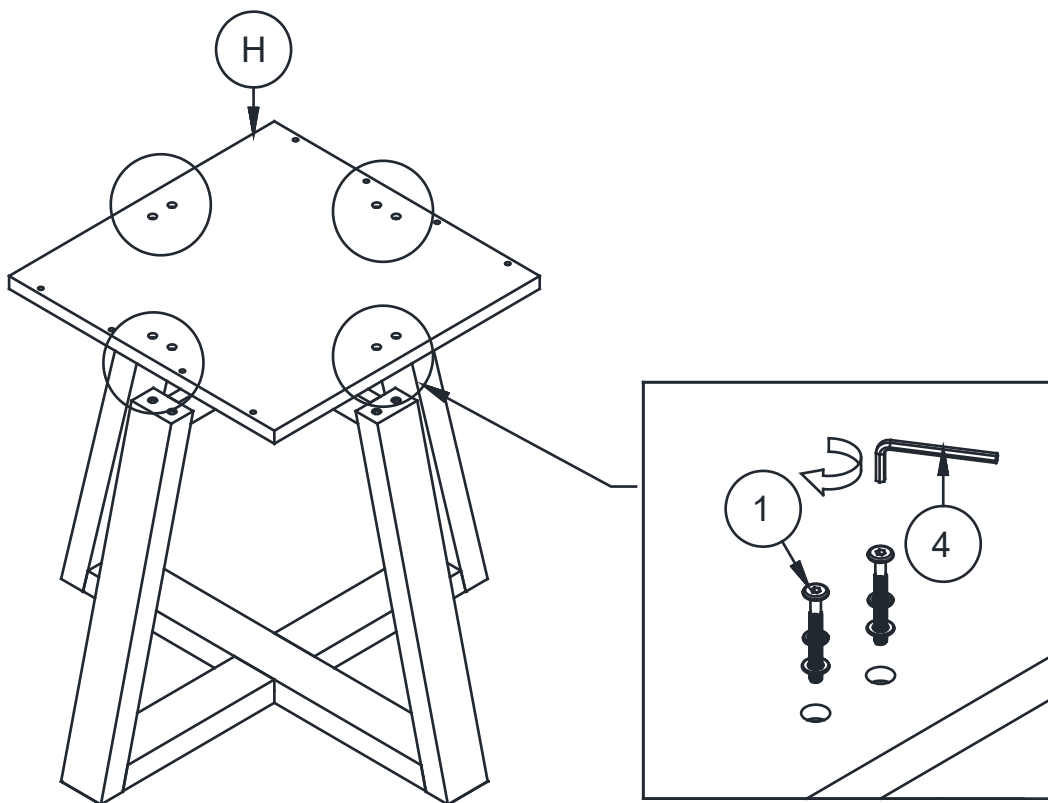

#### NOTE :

Make sure this product assemble on the flat and soft surface. Follow the instructions. Tighten all the nuts, bolts or screws firmly and make sure this product does not wobble before use.

## Assembly steps

### STEP 5

Screwdriver - Not provided

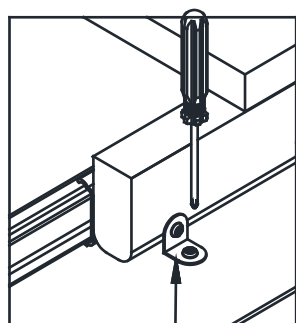

Remove L Bracket  
before start using Table.

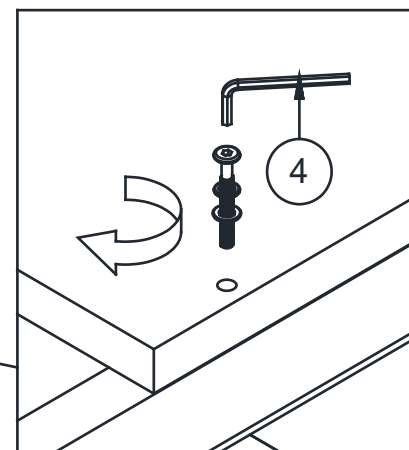
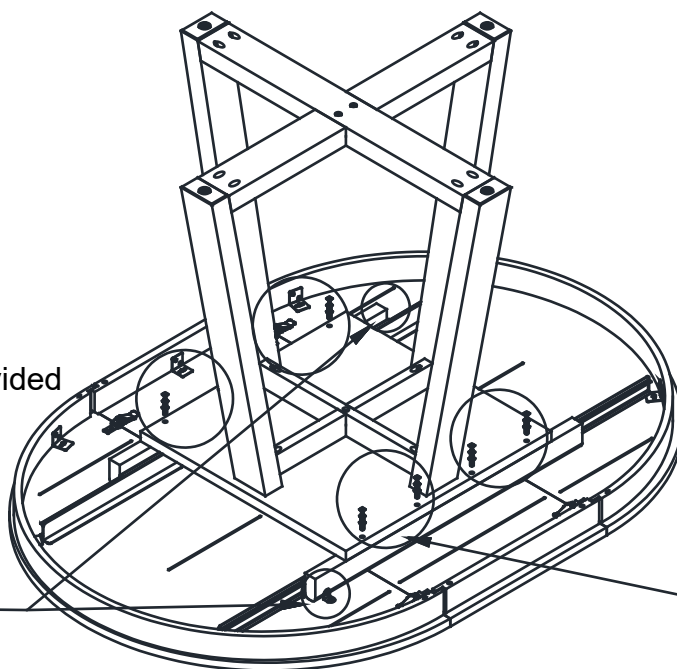

Remark:  
Please use back the bolts  
in Step 1 to Assemble.

### STEP 6

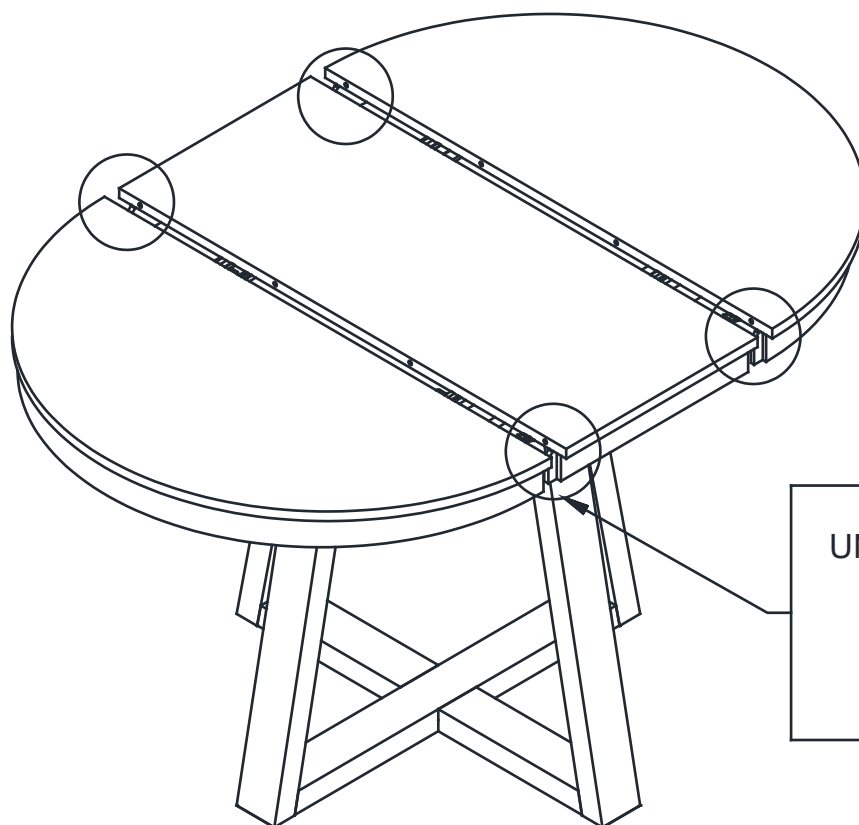

UNLOCK

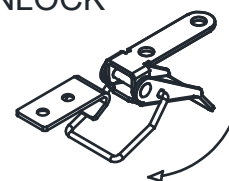

### NOTE :

Make sure this product assemble on the flat and soft surface. Follow the instructions. Tighten all the nuts, bolts or screws firmly and make sure this product does not wobble before use.

## Assembly steps

### STEP 7

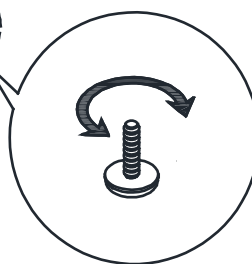
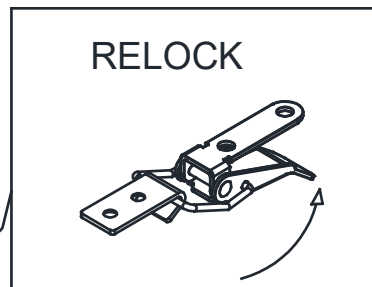
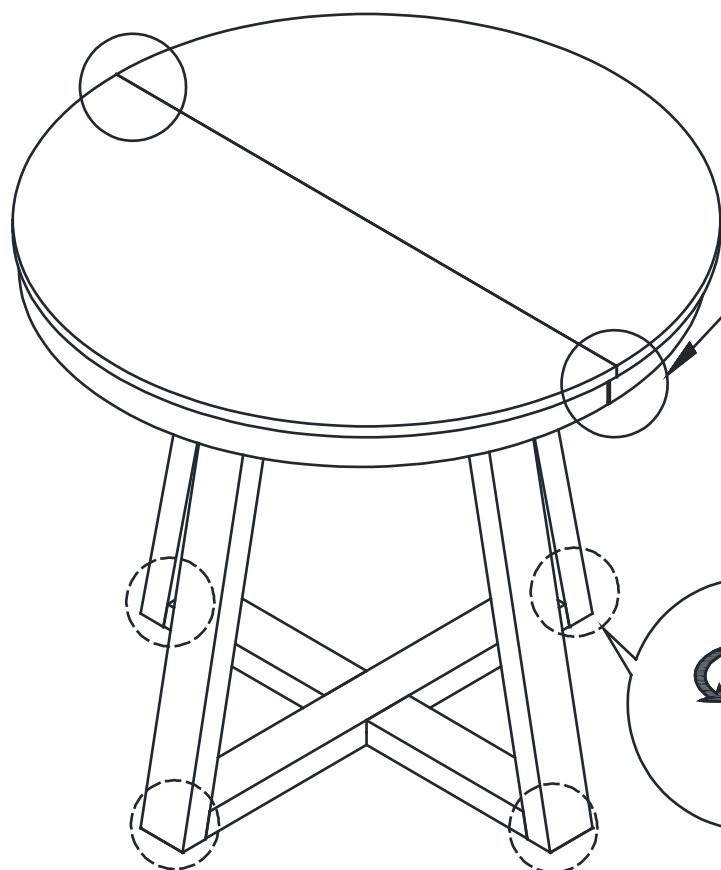

Note : Adjust leveler to stabilize

### STEP 8

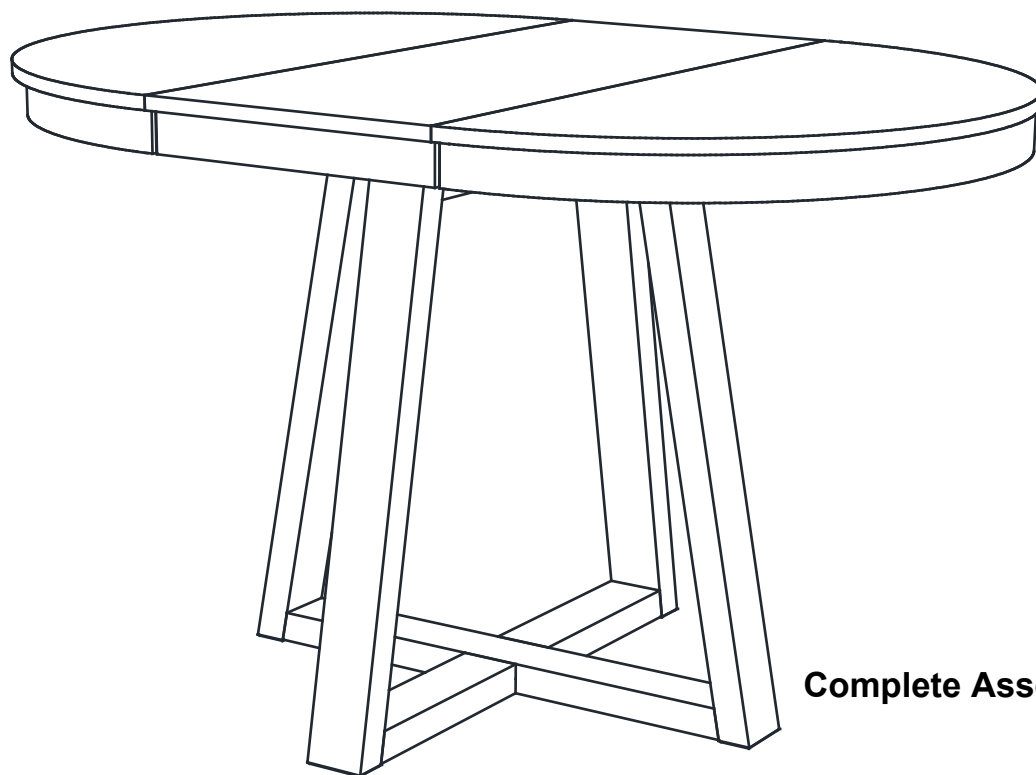

**Complete Assemble**

#### NOTE :

Make sure this product assemble on the flat and soft surface. Follow the instructions. Tighten all the nuts, bolts or screws firmly and make sure this product does not wobble before use.