

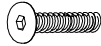



ASSEMBLY INSTRUCTIONS

GLOB 4302-1 BAR TABLE SKU# 43243029

STEP	CODE	HARDWARE		Q'TY
1	A	Allen Wrench		1 pc
	B	Bolt Ø5/16" x 18 x 1"		9 pcs
	C	Metal Plate 4" x 3-1/2" x 3mm		3 pcs
2	D	Bolt Ø5/16" x 18 x 3/4"		15 pcs
		Spring washer Ø5/16"		15 pcs
		Flat washer Ø5/16"		15 pcs
3	E	Bolt Ø5/16" x 18 x 1-3/4"		6 pcs
		Spring washer Ø5/16"		6 pcs
		Flat washer Ø5/16"		6 pcs
4	F	"L"Metal Plate 2-1/2" x 1-3/4" x 3mm		3 pcs

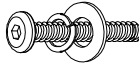

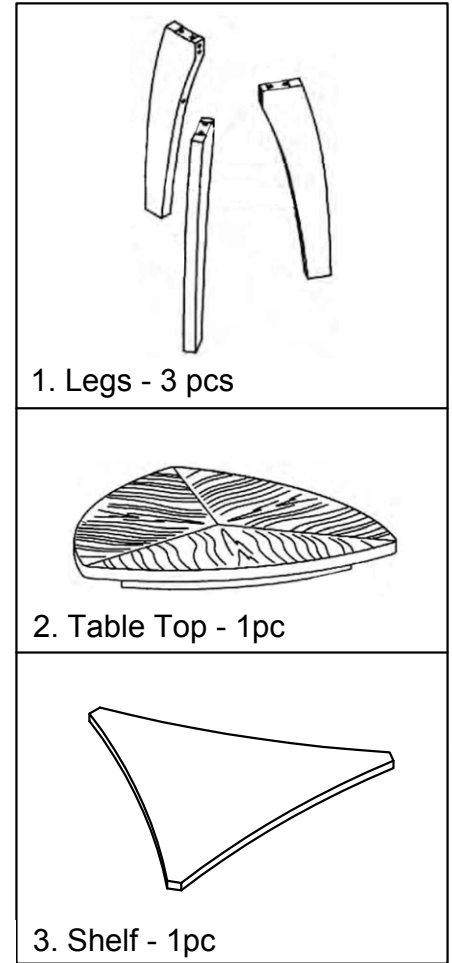
Hardware Pack Location (s) :
4302-1 BAR TABLE SKU# 43243029

ASSEMBLY INSTRUCTIONS

GLOB 4302-1 BAR TABLE SKU# 43243029

***Cautions: Please read all instructions carefully before starting the assembly process. These parts are cumbersome and heavy. Therefore, two people are recommended in order to prevent personal injury and ensure the parts are not damaged during the assembly.

STEP 1:

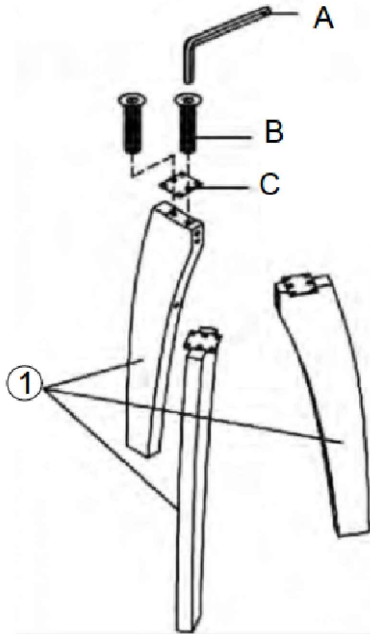

Attach the Metal Plate to the Legs (1) by hardware with Allen Wrench.

STEP 2:

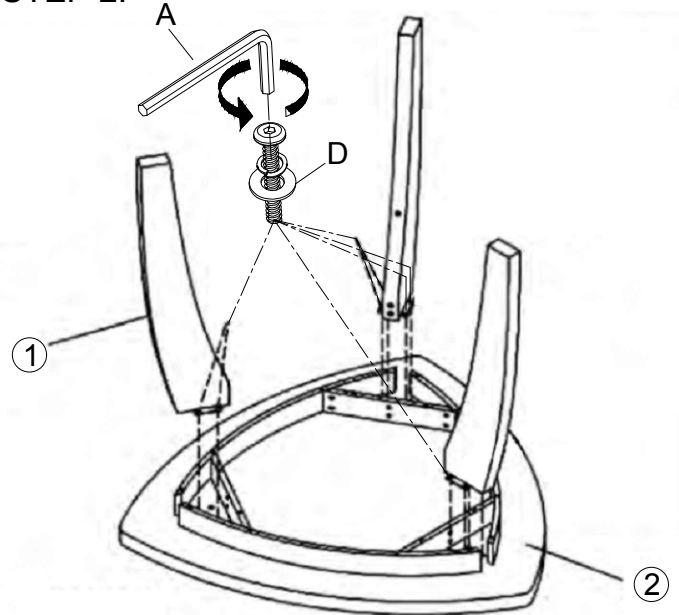

Attach the Legs (1) to the Table Top (2) by hardware with Allen Wrench.

STEP 3:

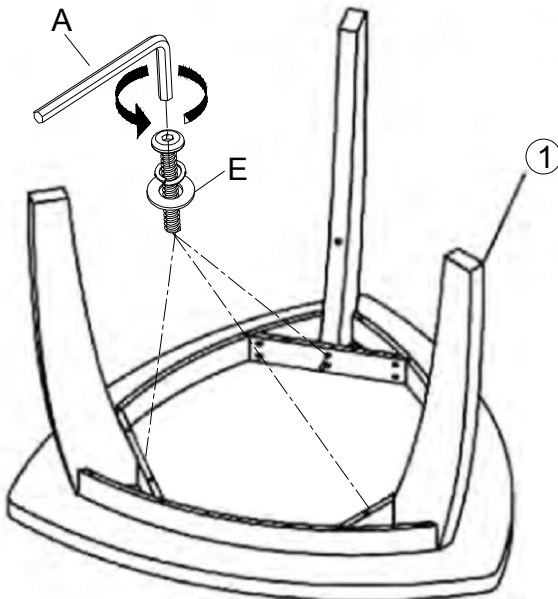

Attach the Apron block to the Legs (1) by hardware with Allen Wrench.

STEP 4:

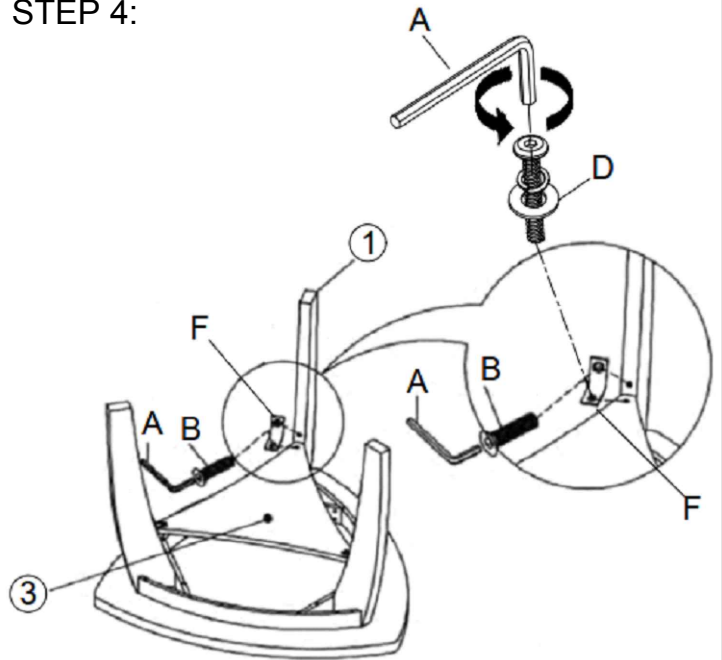

Screw the "L" Metal Plate to the Shelf (3) and Legs (1) by hardware with Allen Wrench.