



# Assembly Instructions For







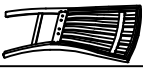
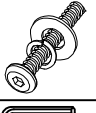

NAJA CRMANCW 43411406 1140-CS WD BK CNTR HT STOOL BLACK CHARCOAL

Manufactured for Rooms to Go.

Thank you for purchasing this quality product. Be sure to check all packing material carefully for small parts, which may have come loose inside the carton during shipment. Identify and count all parts and compare with the **HARDWARE LIST** below.

Caution : Please read instructions thoroughly before unpacking assembly parts. Sharp, exposed staple tips can cause injury, therefore, for your protection, please remove any exposed staples used in packing.

1. We recommend that you should assemble this product with the assistance of another person; this will make assembly easier, and will help to eliminate damage to the product or injury to persons during assembly.
2. Please do not over tighten screws or bolts until the assembly is completed.
3. Please put all parts on a non - abrasive floor before assembly, and follow the assembly steps to assemble your newly purchased product correctly and efficiently.
4. All hardware pack number are the same as Assemble step number.

| NO. | PARTS LIST   | Q'TY | NO. | HARDWARE PACK   | Q'TY                              |   |
|-----|--|------|-----|---|-----------------------------------|---|
| A   | Chair Back            | 1    | 1   |  | Ø1/4"x20 x 1- 1/2"L Allen bolt    | 2 |
| B   | Cushion Seat          | 1    |     |   | Ø1/4"xØ11mmx2mmT Spring washer    | 2 |
| C   | Front Stretcher       | 1    |     |   | Ø1/4"xØ19mmx2mmT Flat washer      | 2 |
| D   | Side Left Stretcher   | 1    | 2   |  | Allen Key ( 4mm )                 | 1 |
| E   | Side Right Stretcher  | 1    |     |   | Ø5/16"x18 x 3- 1/4"L Allen bolt   | 4 |
| F   | Front Left Leg       | 1    |     |   | Ø5/16"xØ13mmx2mmT Spring washer   | 4 |
| G   | Front Right Leg     | 1    | 3   |  | Ø5/16"xØ19mmx2mmT Flat washer     | 4 |
|     |  |      |     |   | Ø5/16" x 6mm hex nut              | 4 |
|     |  |      |     |   | Ø5/16"xØ13mmx1.2mmT Spring washer | 4 |
|     |  |      |     |   | Ø5/16"x19x1.8mmT Flat washer      | 4 |
|     |  |      |     |   | Open wrench 12mm                  | 1 |
|     |  |      |     |   | #8x45mm Screw                     | 6 |

Please note: Do not fully tighten the bolts before making sure that all the bolts get in position.

### STEP: 1

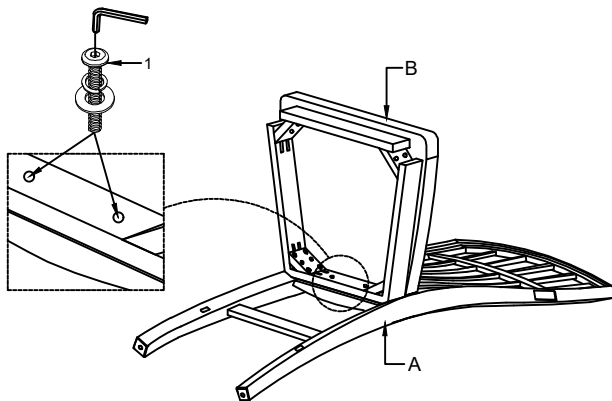

### STEP: 3

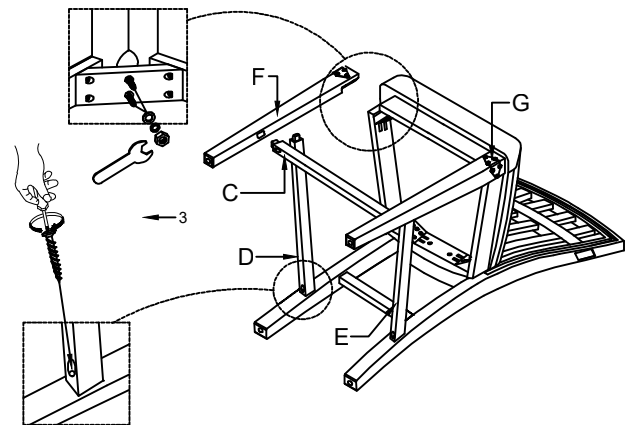

### STEP: 2

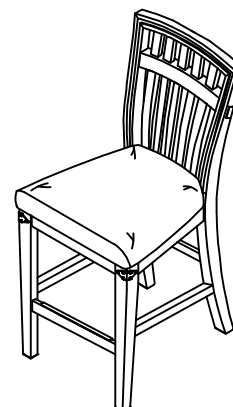
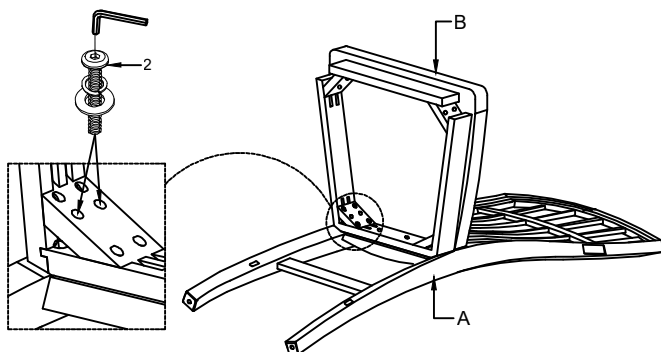

Assembly Completed

MADE IN VIETNAM