

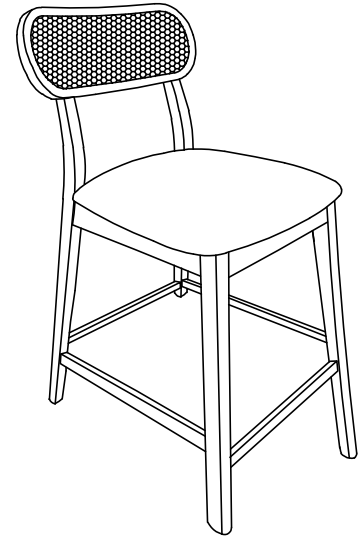

Thanks you for purchasing this quality product. Be sure to lay all components on a soft and clean surface before assembly in order to avoid components from being scratched.

CAUTIONS :





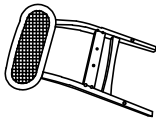
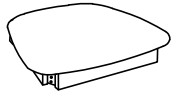
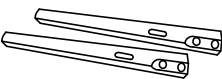



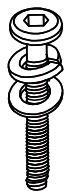

1. Check contents against list for quantity.
2. Familiarize yourself with the components and hardware by reviewing the Assembly Instructions.
3. Do not over tightened the screws and bolts as it may damage the threads.
4. Keep all hardware parts out of the reach of children.
5. Please "LIFT UP & MOVE" the chair when ever you want to shift it.



PARTS LIST

| NO. | DESCRIPTION | QTY |
|----------|---|-------|
| 1 | BACK REST  | 1 PC |
| 2 | BOX SEAT  | 1 PC |
| 3 | LEG  | 2 PCS |
| 4 | FRONT STRETCHER  | 1 PC |
| 5 | SIDE STRETCHER  | 2 PCS |

HARDWARE LIST

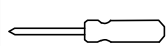
| NO. | DESCRIPTION | QTY |
|----------|--|-------|
| A | JCBB M8 x P1.25 x 70MM  | 4 PCS |
| | FLAT WASHER M8 x 22MM  | 4 PCS |
| | SPRING WASHER M8  | 4 PCS |
| B | JCBB M8 x P1.25 x 60MM  | 4 PCS |
| | FLAT WASHER M8 x 22MM  | 4 PCS |
| | SPRING WASHER M8  | 4 PCS |
| C | JCBB M8 x P1.25 x 35MM  | 2 PCS |
| | FLAT WASHER M8 x 22MM  | 2 PCS |
| | SPRING WASHER M8  | 2 PCS |
| D | CHIPBOARD SCREW M4 X 38MM  | 6 PCS |
| E | ALLEN KEY M4  | 1 PC |
| F | PHILIPS HEAD SCREW DRIVER (NOT INCLUDED)  | 1 PC |

HARDWARE PACK LOCATION:

HARDWARE PACK

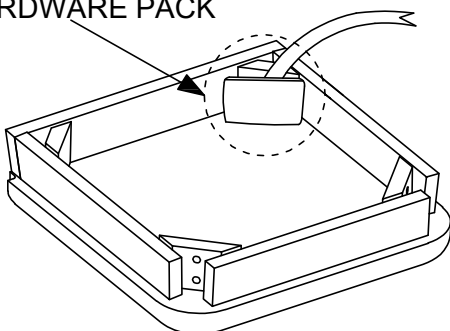

STEP 1

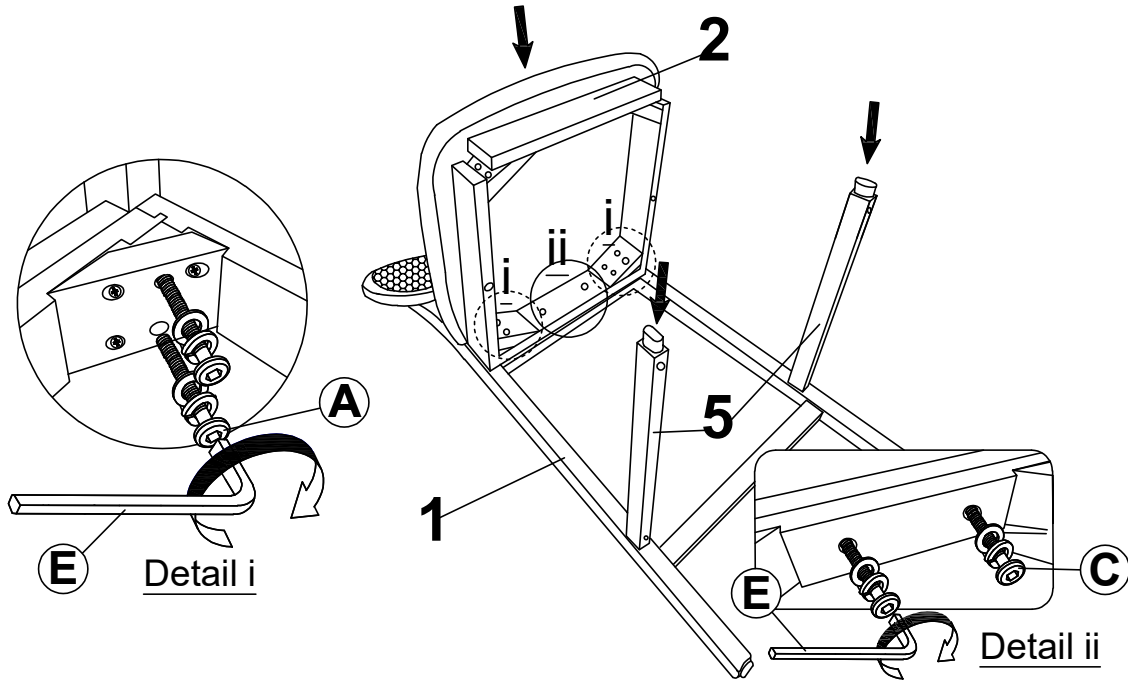

- a) Attached the box seat (2) to back rest (1) and use JCBB Bolt (A) to tighten the left & right holes on corner block of (2).
- b) Use JCBB Bolt (C) to tighten both of the center holes on bottom of (2) as shown.
- c) Insert the side stretcher (5) into the holes at bottom of (1).

STEP 2

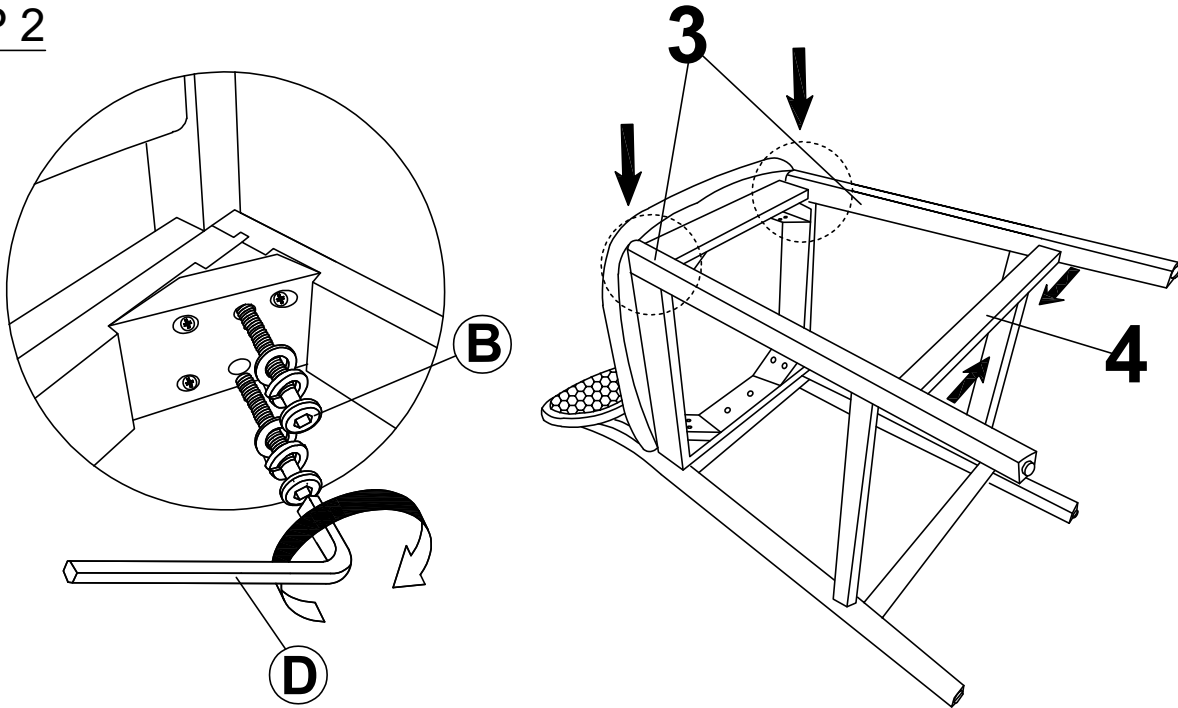

- a) Fit the front stretcher (4) into the holes between Left & Right front leg (3) as shown.
- b) Attach the (3) to the front of box seat, use JCBB Bolt (B) to tighten the left & right holes on corner block of (2).

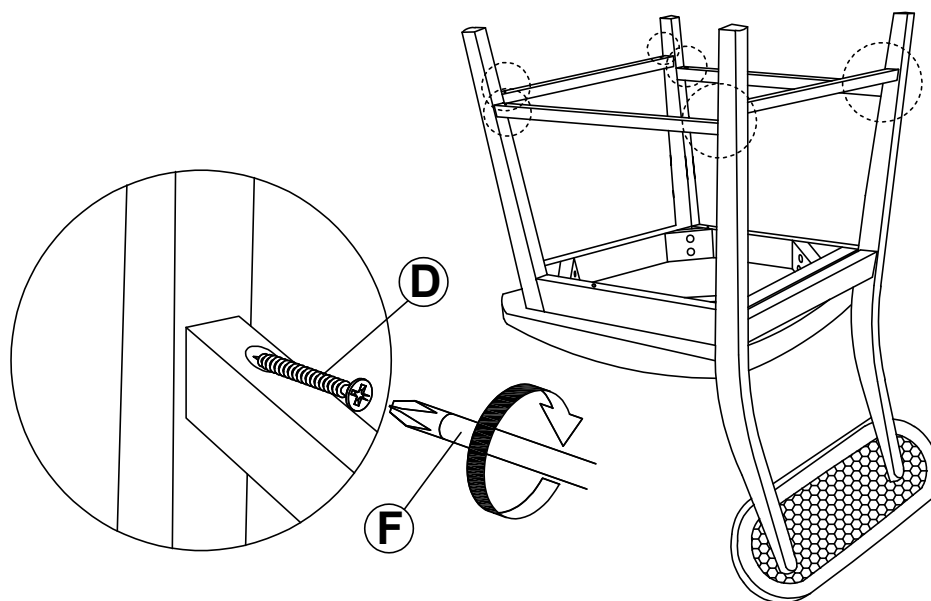
STEP 3

- a) Position the leg facing up as shown, use Chipboard Screw (D) to fasten all stretcher to the front legs and back legs.
- b) Set the chair right-side up.

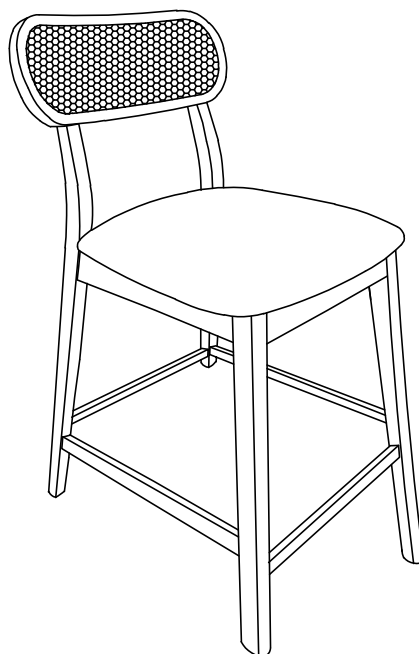

The assembly of stool is completely.