





Assembly Instructions

MONTARA CHAISE

SKU#70563121

Part List

NO.	SKETCH	DESCRIPTION	QTY
A		Chaise	2
B		Steel frame	2
C		Bolt (M6 *20)	8
D		Leg leveler	8
E		Allen key	1

JWUA GLA-63127-14KD
Made in China

STEP 1

Unscrew the 4 M6x15mm bolts(C) at the bottom of legs, then remove the steel frame(B).

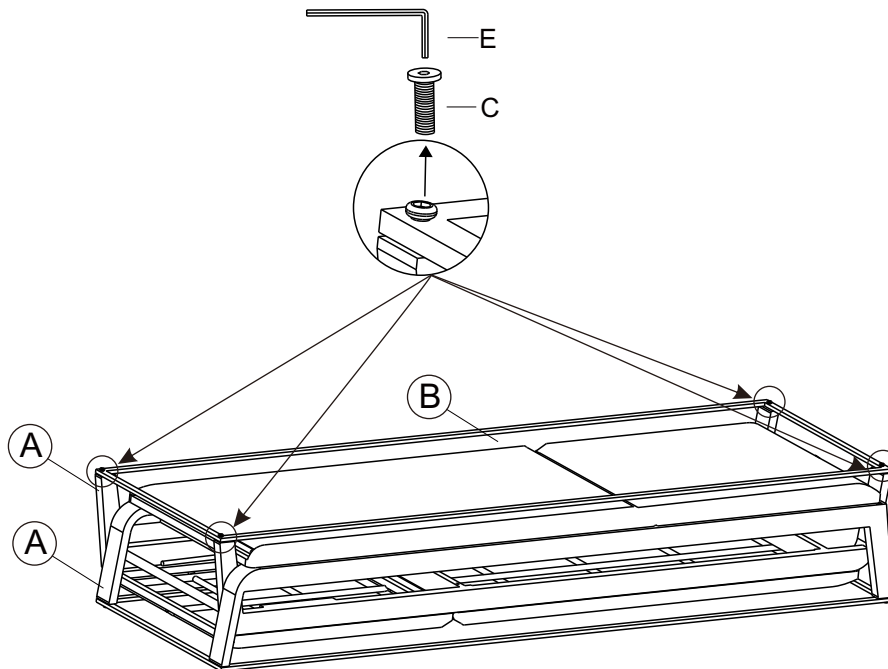

STEP 2

Screw the 4 leg levelers(D) at the bottom of legs.

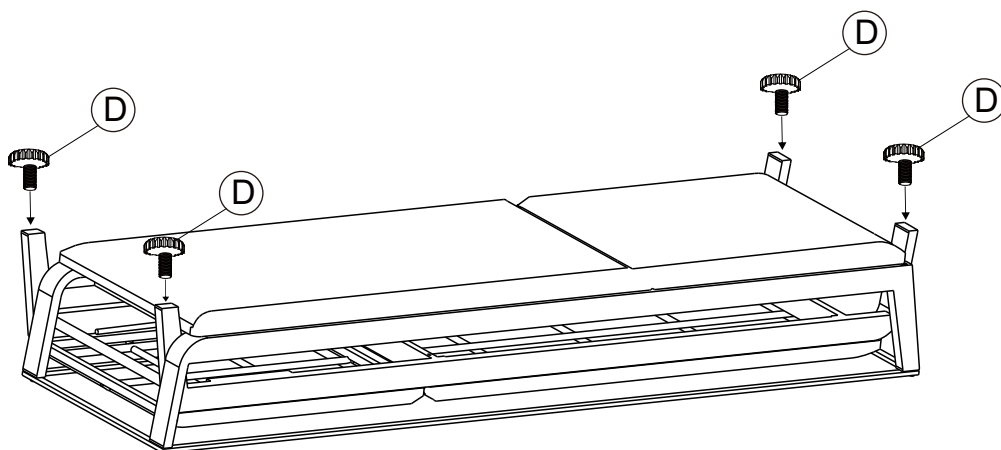

STEP 3

Turn the two chaises(A) over and unscrew the 4 M6x15mm bolts(C) at the bottom of legs,then remove the steel frame(B).

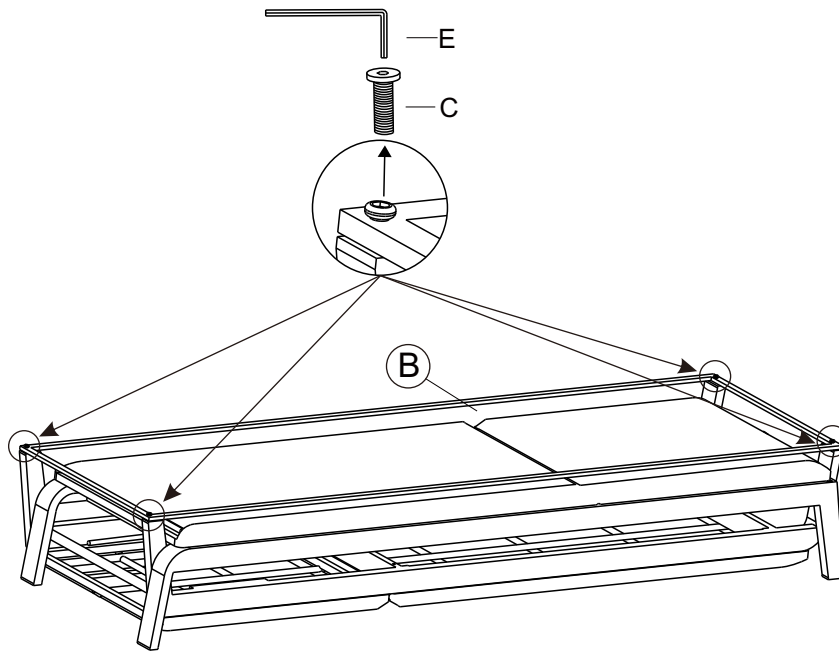

STEP 4

Screw the 4 leg levelers(D) at the bottom of legs.

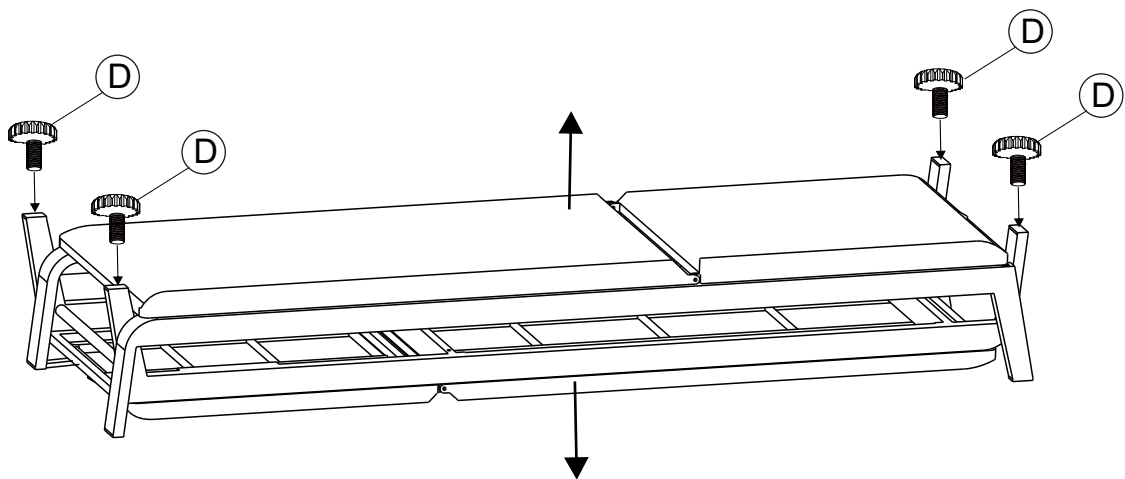

STEP 5

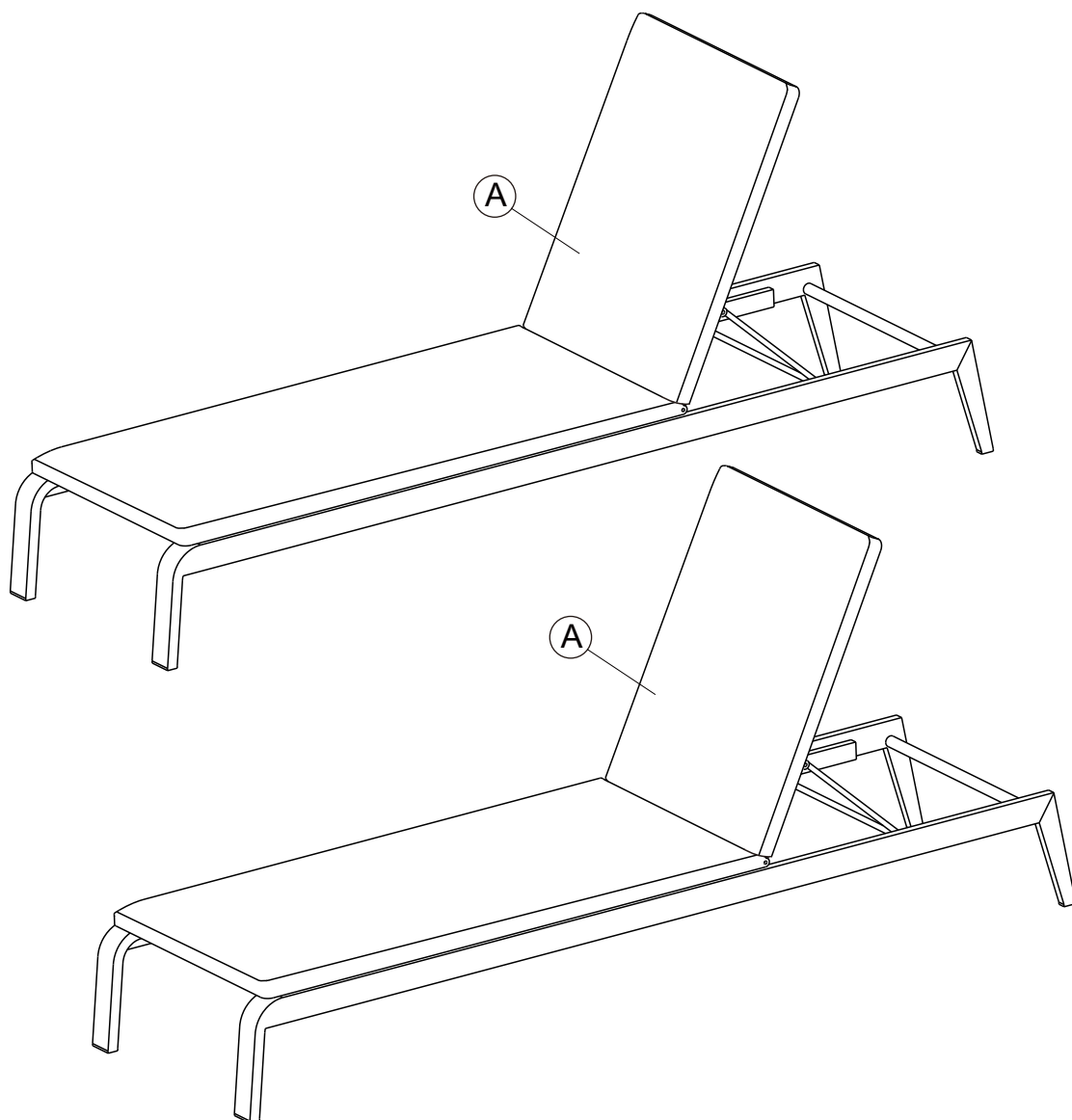

***DO NOT OVER TIGHTEN**

***NO SOCKET DRIVERS**



***NO POWER TOOLS**

