

## Assembly Instructions









Identify all parts packed in the carton against the parts list. Remove all protective materials. Place parts on a non-abrasive surface to avoid scratching.

**Do Not Attempt Assembly If Any Parts Are Missing Or Damaged.**

Warning: Please do not use acid or alkaline washing liquid to clean the product.

Assemble the product as shown below, step-by-step.

### Part List

NO.	SKETCH	DESCRIPTION	QTY	NO.	SKETCH	DESCRIPTION	QTY
A		Leg	4	AA		Bolt (M6*20)	4
B		Fixed Ring	1	BB		Bolt (M6*25)	8
C		Table Top	1	CC		Steel Washer (Φ14*Φ6.5*1.5)	12
D		Foot Glider	4	DD		Boltcap	12
						Wrench	1

JWUA GLA-5106-2848W  
Made in China

## STEP 1

Hand Tighten Nut 3-4 Revolutions Only, Do Not Tighten All The Bolts And Nut.

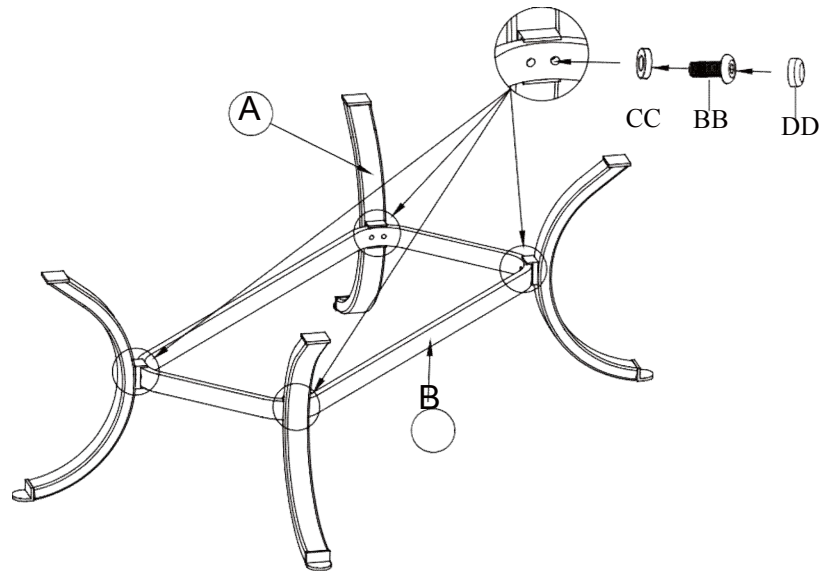

## STEP 2

Hand Tighten Nut 3-4 Revolutions Only, After Attached All The Bolts, Adjust All The Part At Correct Position, Then Tighten All The Bolt And Nut. Do Not Over Tighten.

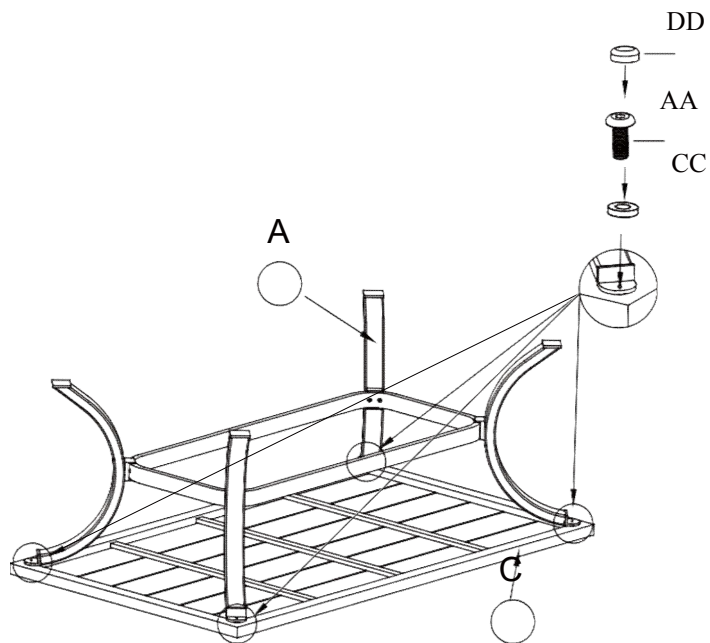

### STEP 3

Need two people turn the Table right side up. Adjust the pre-installed foot glider(D) at the end of each Table leg until the Table is level with the ground Securely, Your Table is ready for use.

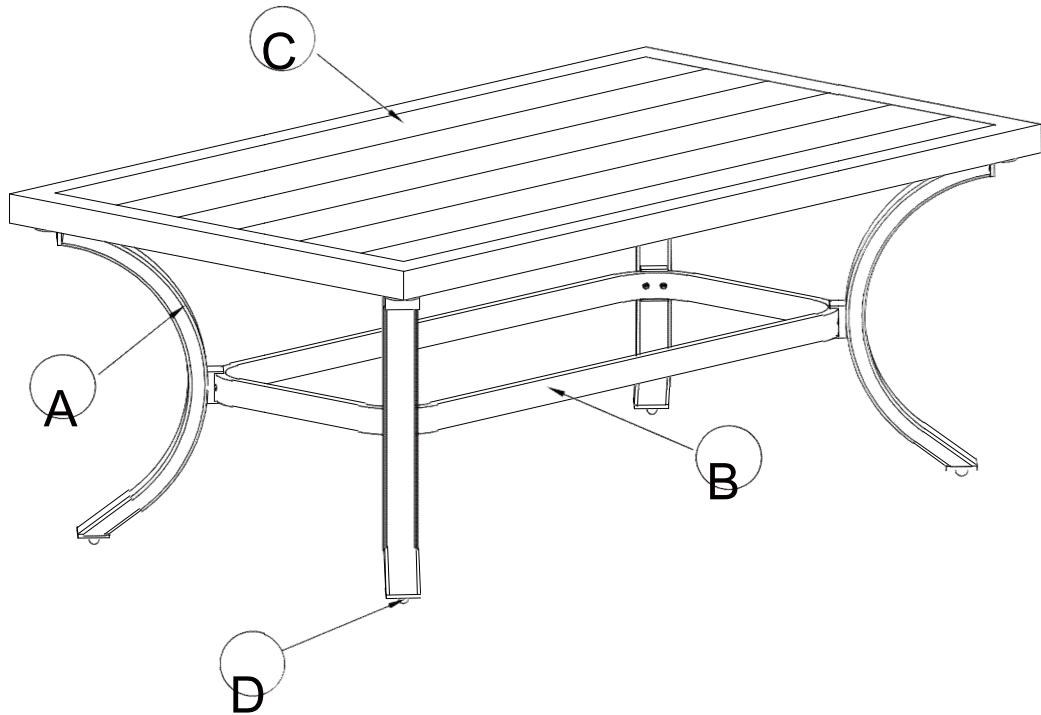

\*DO NOT OVER TIGHTEN

\*NO SOCKET DRIVERS



\*NO POWER TOOLS

