





## Assembly Instructions

Identify all parts packed in the carton against the parts list. Remove all protective materials. Place parts on a non-abrasive surface to avoid scratching.

**Do Not Attempt Assembly If Any Parts Are Missing Or Damaged.**

Warning: Please do not use acid or alkaline washing liquid to clean the product. Assemble the product as shown below, step-by-step.

**Part List**

NO.	SKETCH	DESCRIPTION	QTY	NO.	SKETCH	DESCRIPTION	QTY
A		Leg	4	AA		Bolt (M6*20)	12
B		Table Top	1	BB		Wrench	1
C		Foot Glider	4				

### STEP 1

Hand Tighten Nut 3-4 Revolutions Only, After Attached All The Bolts, Adjust All The Part At Correct Position, Then Tighten All The Bolt And Nut. Do Not Over Tighten.

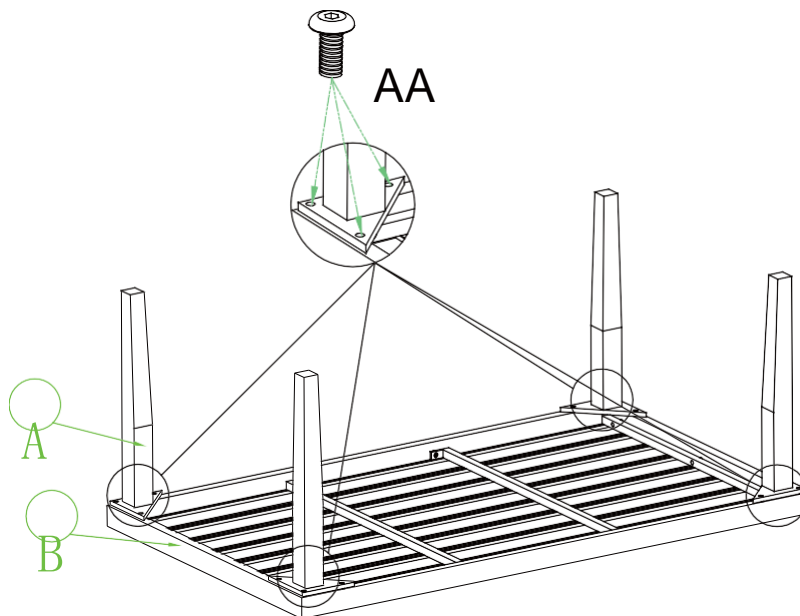

GL2A-66122-2643W  
Made in China

## STEP 2

Need two people turn the table right side up. Adjust the pre-installed foot glider(C) at the end of each table leg until the table is level with the ground. Securely, Your table is ready for use.

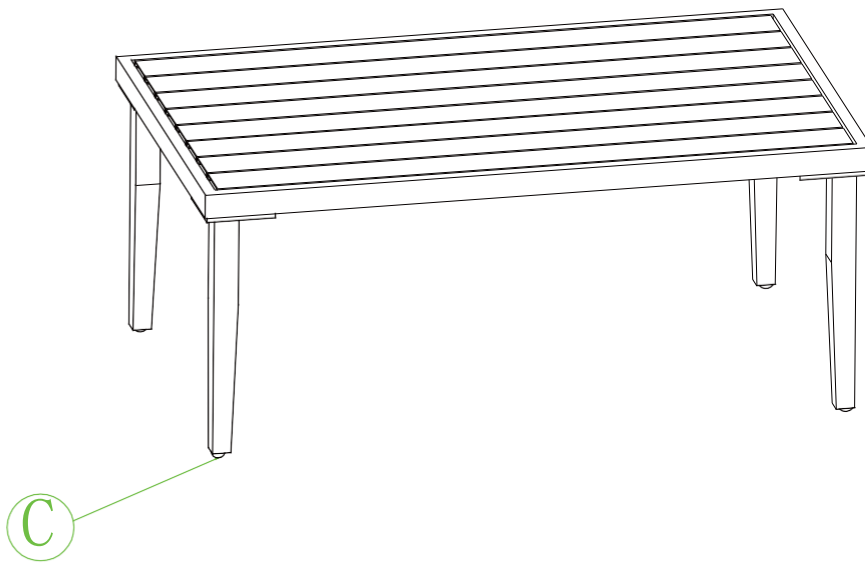

**\*DO NOT OVER TIGHTEN**

**\*NO SOCKET DRIVERS**



**\*NO POWER TOOLS**

