

Item # : ORRSST  
Assembly Instructions



*Please visit our website for the most current instructions, assembly tips, report damage, or request parts. [www.walkerredison.com](http://www.walkerredison.com)*

Revised 03/2018

# General Assembly Guidelines

- I. Ensure that all parts and hardware are available before beginning assembly.
- II. Follow each step carefully to ensure the proper assembly of this product.
- III. Two people are recommended for ease in the assembly of this product.
- IV. The two main types of hardware used to assemble this product are : screws and bolts.
- V. A Phillips head screwdriver is required for the assembly of this product .

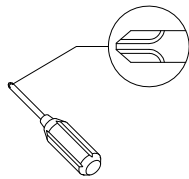



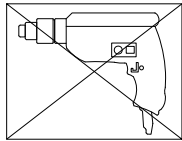

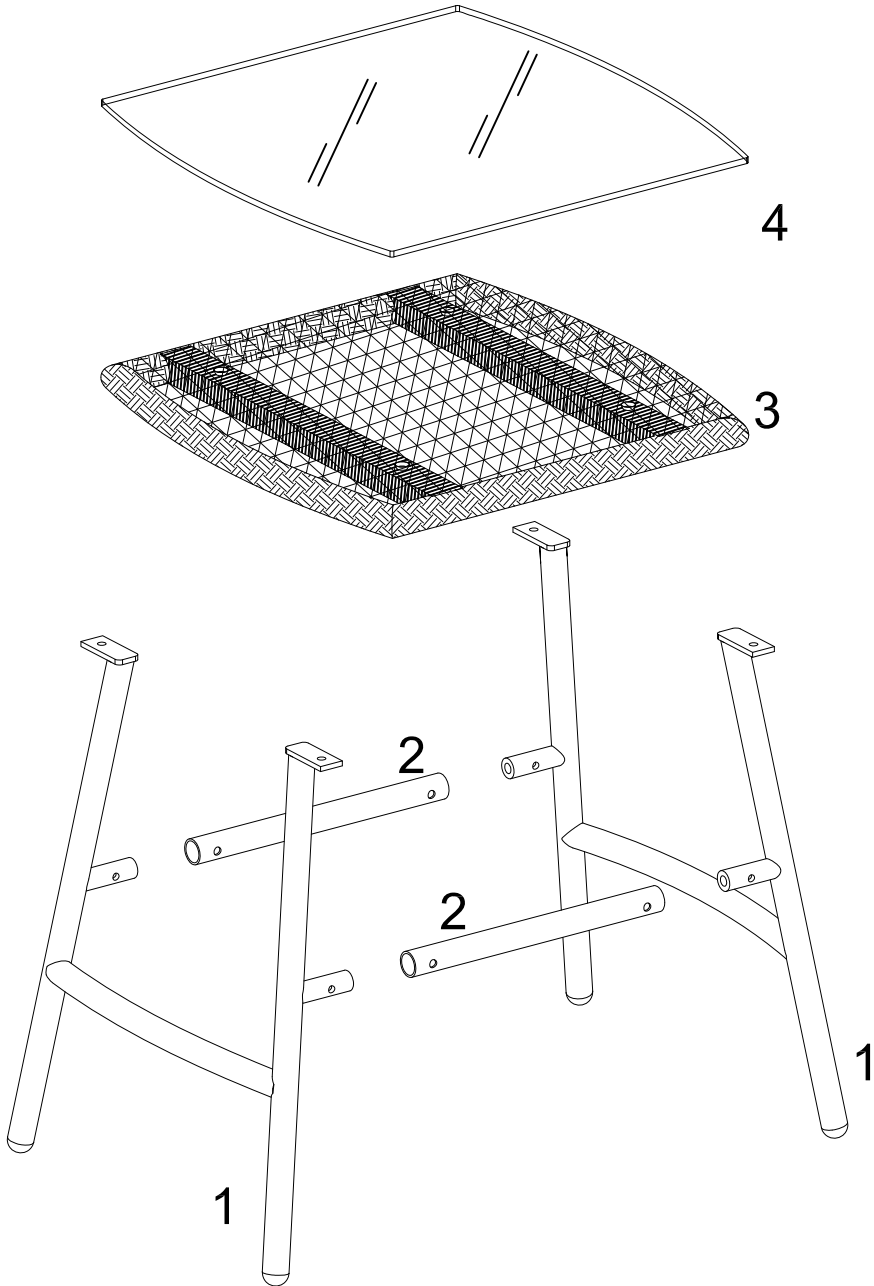

- VI. Power tools should not be used to assemble this product .



# Parts List

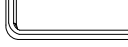

# Hardware List

A		M6x20mm	Bolt	4 pcs
B		M6x35mm	Bolt	4 pcs
C		Ø15	Washer	8 pcs
D		M 4	Hex Key	1 pcs
E		M6	Nut	4 pcs
F		M6	Wrench	1 pcs
G		M6	Screw cap	4 pcs

*The hardware quantities listed above are required for proper assembly.  
Some extra hardware may also have been included.*

## Step 1

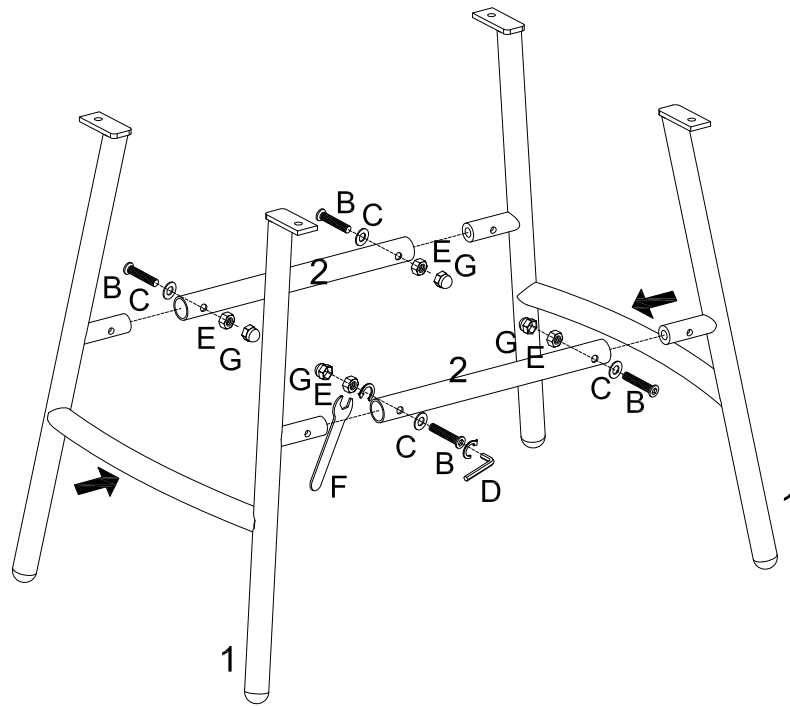

Attach part (1) to part (2) using bolt (B), washer (C) with hex key (D), and nut (E), screw cap (G) with wrench (F).

## Step 2

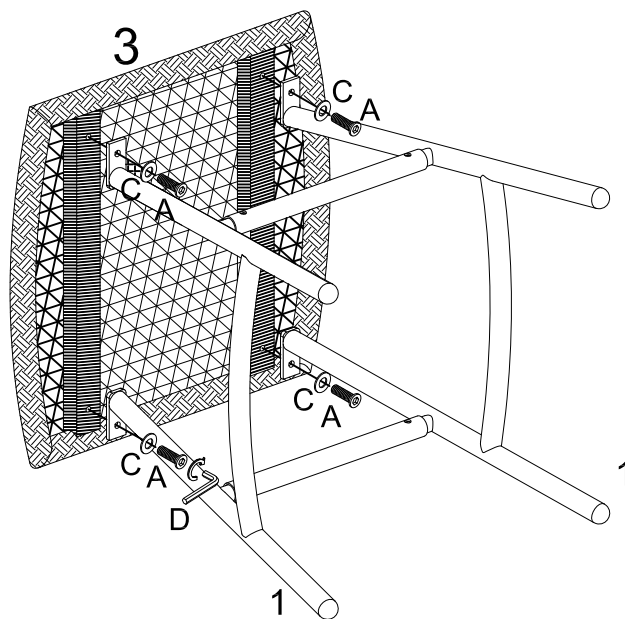

Attach part (1) to part (3) using bolt (A), washer (C) with hex key (D).

## Step 3

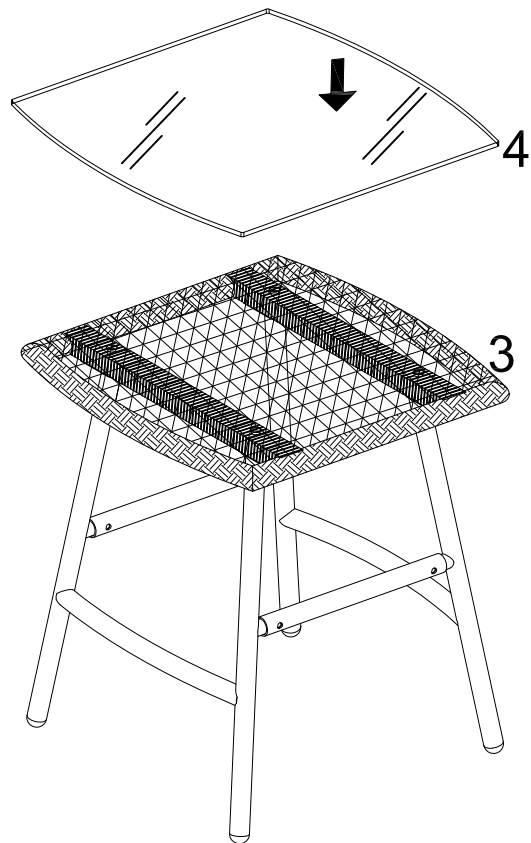

Place glass (4) carefully on top of part (3) as per diagram.

## Step 4



Final Assembly