





# Assembly Instructions

SCIT 4230-23812 Leg Table SKU# 74042309

Step	Code	Hardware	Q'TY
1	A	F-Bolt 8x45mm, P-HEX, ST 	8pcs
1	B	Plain washer 8.5x18x1mm, ST 	8pcs
1	C	Spring washer 8.5x12.5x1.5, ST 	8pcs
1	D	Support pat 25x45x(t3.0), ST 	4pcs
2	E	Allen key 4x98mm 	1pc

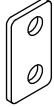
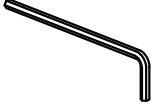
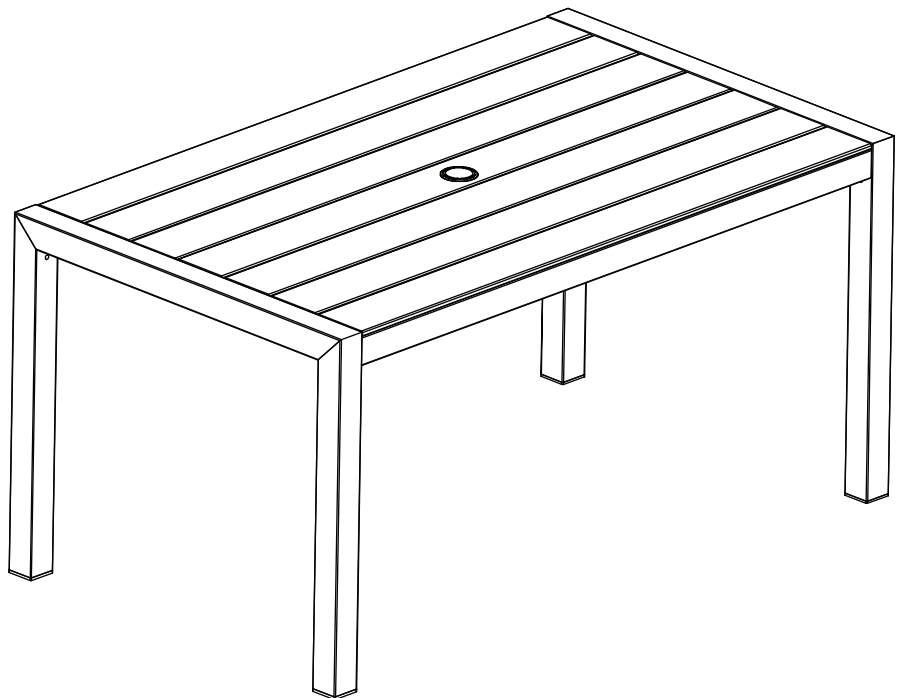

Hardware Pack Location(s):

4230-23812 Leg Table, SKU# 74042309

# Assembly Instructions

SCIT 4230-23812 Leg Table SKU# 74042309

\*\*\*Caution: Please read all instructions carefully before starting the assembly process. These parts are cumbersome and heavy. Therefore, two people are recommended in order to prevent personal injury and insure the parts are not damaged during the assembly.

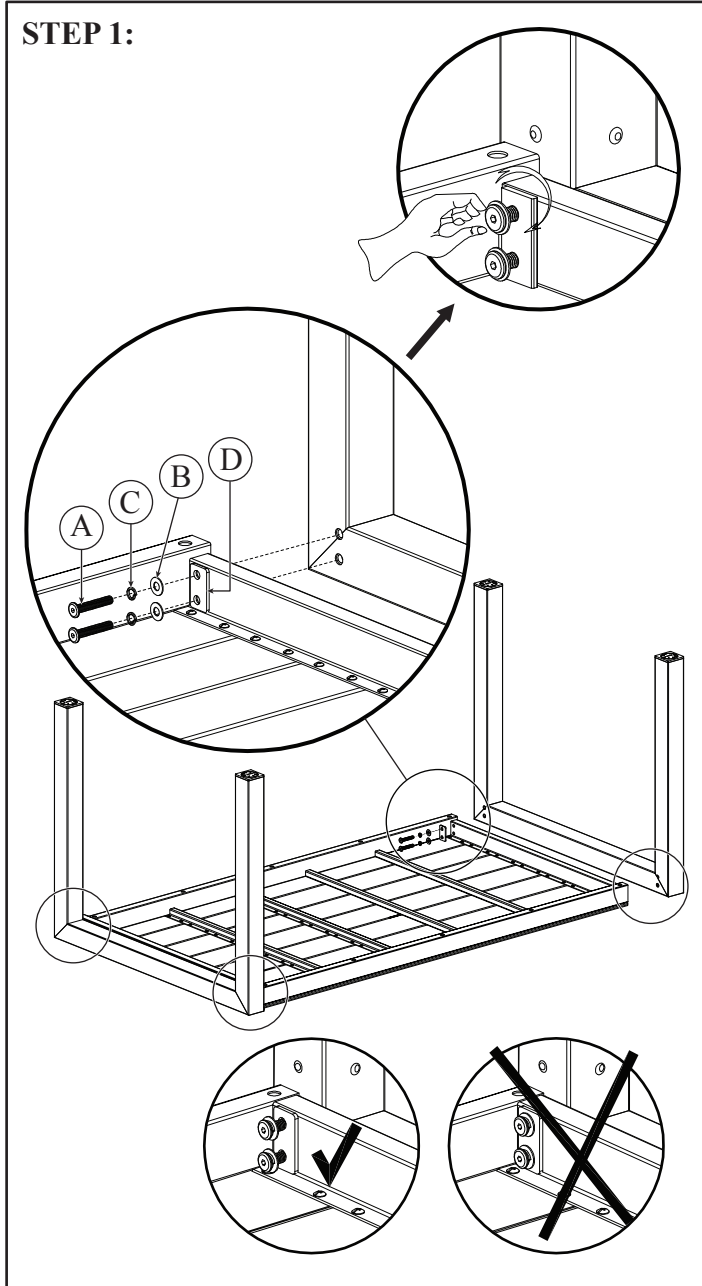

Attach the table legs to assembled the table top with F-bolt A, Spring washer C, Plain washer B and support pat D. Hand tighten only.

NOTE: Do not tighten all the bolts

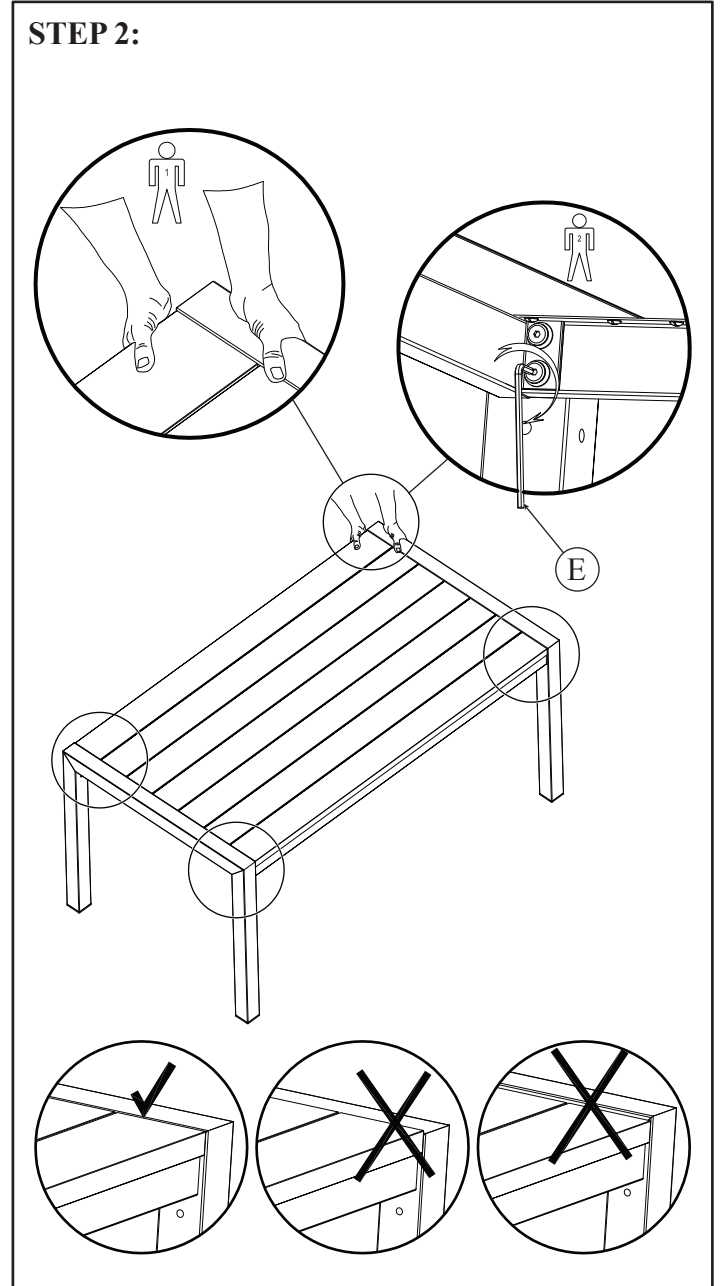

To make sure it is level, a person adjusts the chairs legs and the table top deflected, other use allen key E to tighten all bolts.

Hardware Pack Location(s):

4230-23812 Leg Table, SKU# 74042309