

Assembly Instructions

Identify all parts packed in the carton against the parts list. Remove all protective materials. Place parts on a non-abrasive surface to avoid scratching.

Do Not Attempt Assembly If Any Parts Are Missing Or Damaged.

Warning: Please do not use acid or alkaline washing liquid to clean the product.

Assemble the product as shown below, step-by-step.

Part List

NO.	SKETCH	DESCRIPTION	QTY	NO.	SKETCH	DESCRIPTION	QTY
A		Table Leg	1	A		Bolt (M6*15)	4
B		Table Leg	1	B		Bolt (M6*35)	8
C		Table Top	1	C		Steel Washer ($\Phi 14 * \Phi 6.5 * 1.5$)	12
D		Foot Glider	4	D		Bolt cap	12
				E		Wrench	1

GL2AQ-48-103
Made in China

STEP 1

Insert the table leg A into table leg B.

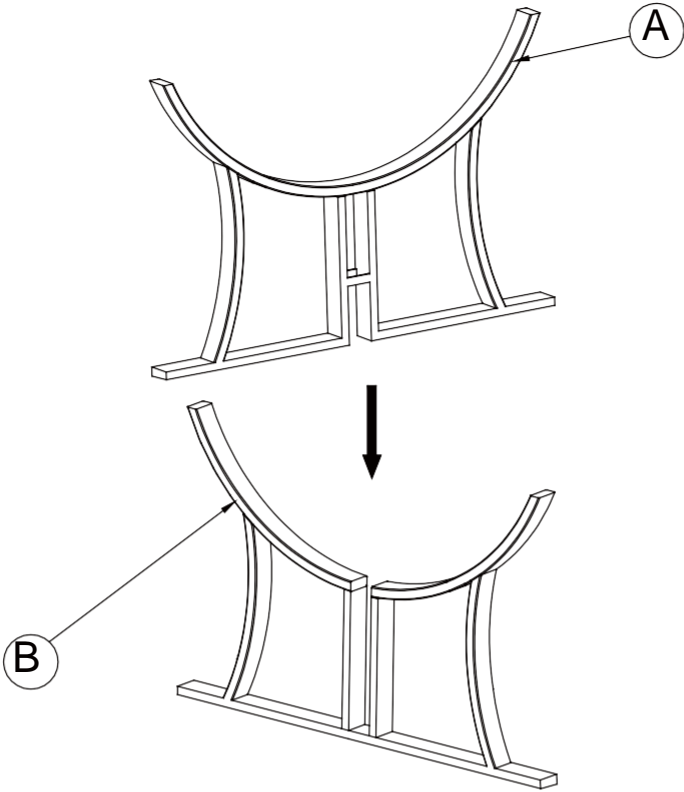

STEP 2

Hand Tighten Nut 3-4 Revolutions Only, Do Not Tighten All The Bolts And Nut.

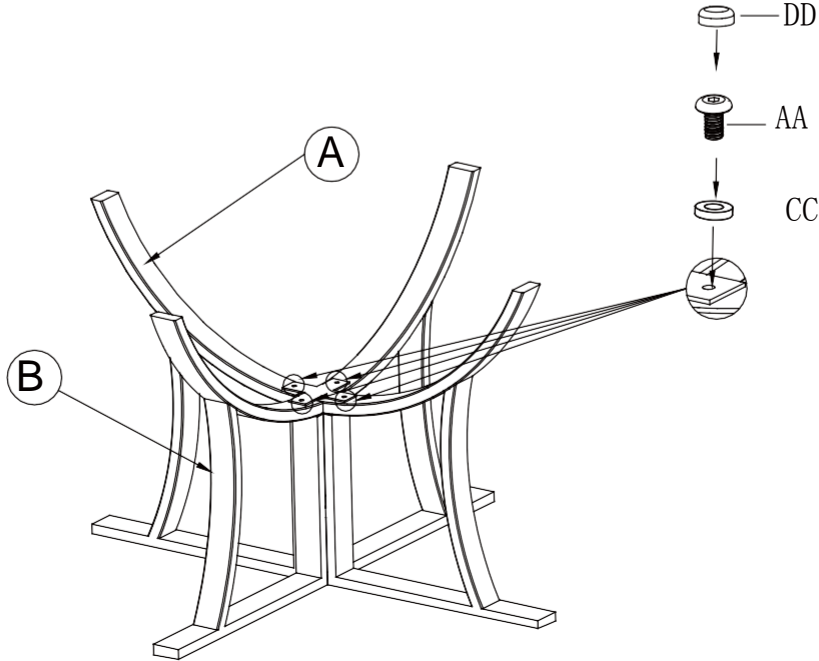

STEP 3

Hand Tighten Nut 3-4 Revolutions Only, After Attached All The Bolts, Adjust All The Part At Correct Position, Then Tighten All The Bolt And Nut. Do Not Over Tighten.

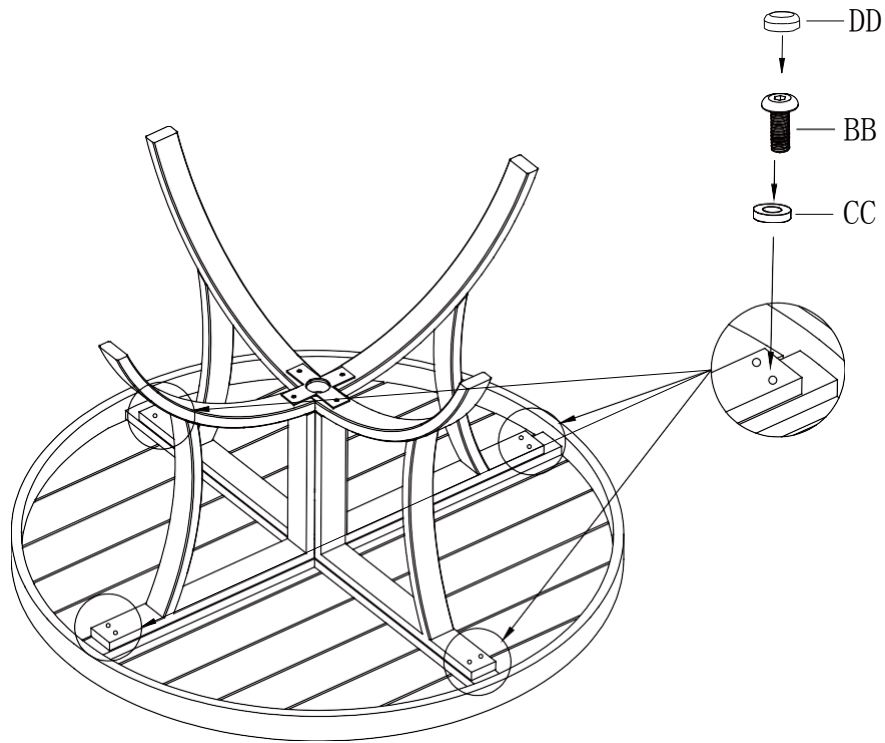

STEP 4

Need two people turn the Table right side up. Adjust the pre-installed foot glider (D) at the end of each Table leg until the Table is level with the ground. Securely, Your Table is ready for use.

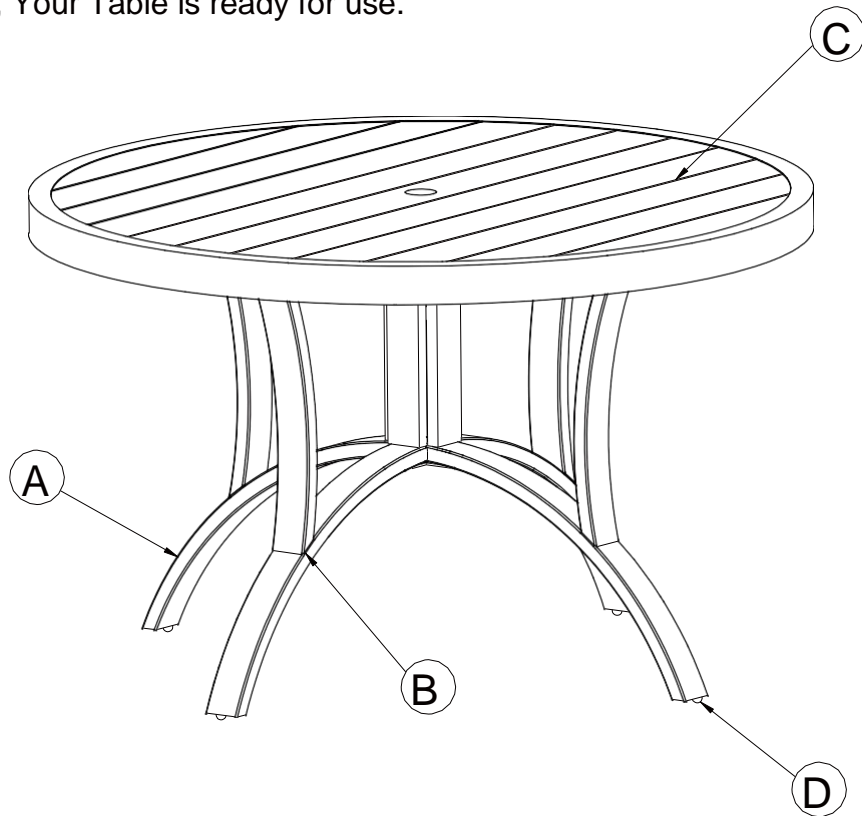

3

*DO NOT OVER TIGHTEN

*NO SOCKET DRIVERS



*NO POWER TOOLS

