

## Assembly Instructions

Identify all parts packed in the carton against the parts list. Remove all protective materials. Place parts on a non-abrasive surface to avoid scratching.









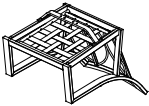
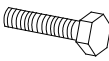
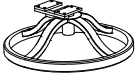

**Do Not Attempt Assembly If Any Parts Are Missing Or Damaged.**

Warning: Please do not use acid or alkaline washing liquid to clean the product.

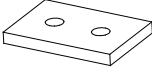
Chair have a 275 lbs weight capacity.

Assemble the product as shown below, step-by-step.

### Part List

NO.	SKETCH	DESCRIPTION	QTY	NO.	SKETCH	DESCRIPTION	QTY
A		Seat Frame	1	AA		Bolt (M8*45)	4
B		Base	1	BB		Steel Washer (Φ12.5*Φ8.5*2)	4
C		Seat Cushion	1	CC		Steel Washer (Φ16*Φ8.2*1.0)	4
D		Back Cushion	1	DD		Steel Washer	4
E		Foot	Pre-assembled at factory	EE		Nut	4
				FF		Bolt Cap (19*16.5*9)	4
				GG		Bolt Cap (19*16.5*17)	4
				HH		Wrench	2

JWUA GLA-5106-11  
Made in China

## STEP 1

Hand Tighten Nut 3-4 Revolutions Only. After Attaching All Bolts, Adjust All The Parts To Correct Position, Then Tighten All Bolts And Nuts. Do Not Over Tighten.

NOTE: When attaching the swivel base plate to the chair, **the Steel Washers (DD) must face the back of the chair.** Otherwise, the chair will be off balance.

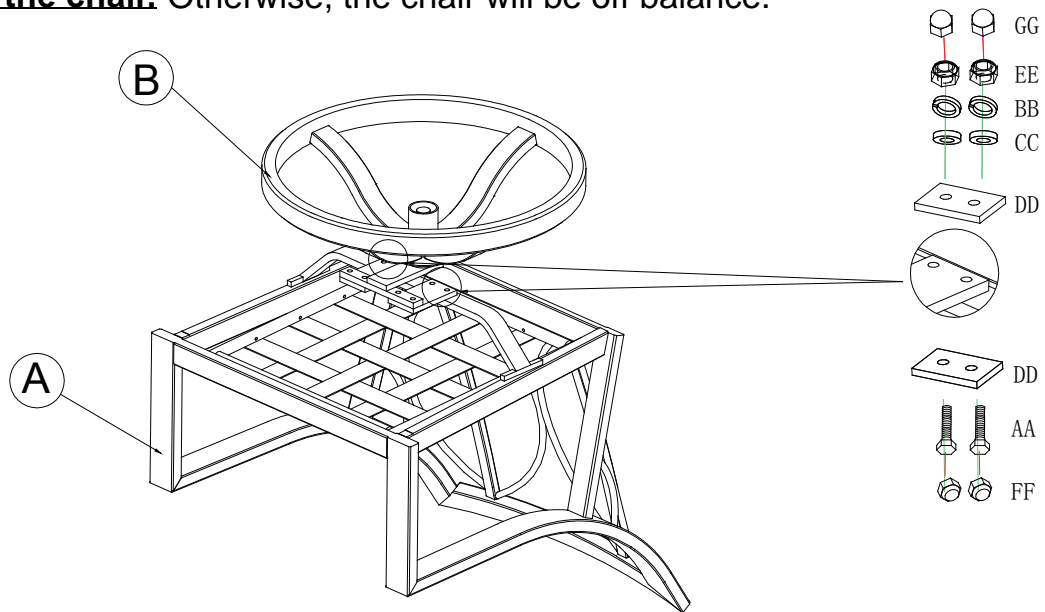

## STEP 2

Need two people turn the Chair right side up, Put the cushion on the chair.  
Your Chair is ready for use.

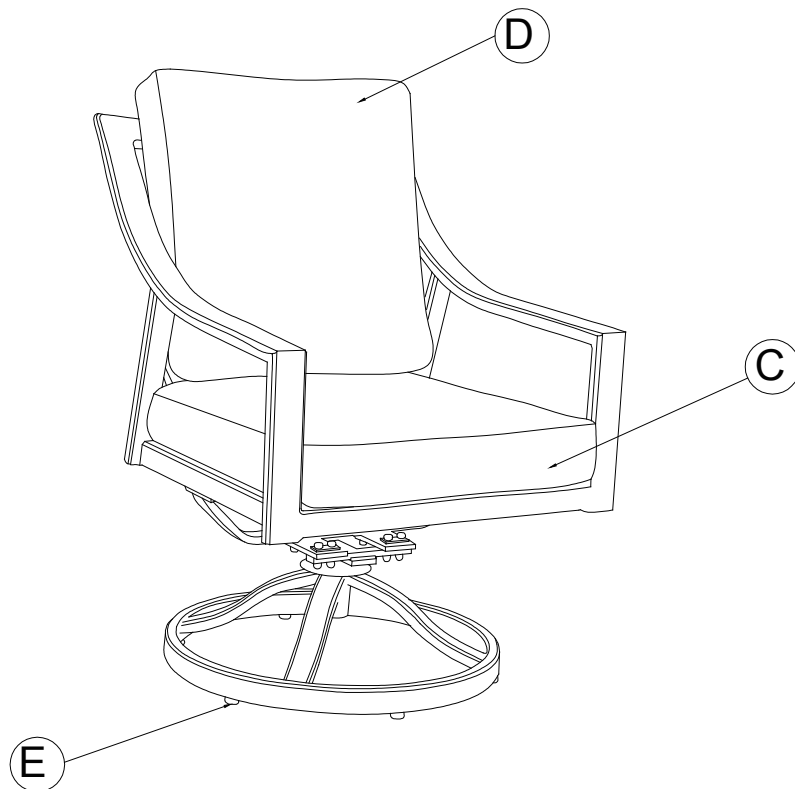

2

\*DO NOT OVER TIGHTEN

\*NO SOCKET DRIVERS



\*NO POWER TOOLS

