

## Assembly Instructions









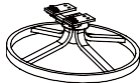

Identify all parts packed in the carton against the parts list. Remove all protective materials. Place parts on a non-abrasive surface to avoid scratching.

**Do Not Attempt Assembly If Any Parts Are Missing Or Damaged.**

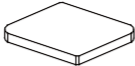
Warning: Please do not use acid or alkaline washing liquid to clean the product.

Assemble the product as shown below, step-by-step.

### Part List

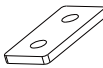
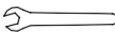
NO.	SKETCH	DESCRIPTION	QTY	NO.	SKETCH	DESCRIPTION	QTY
A		Base	1	AA		Bolt (M8*45)	4
B		Seat Frame	1	BB			4
C		Seat Cushion	1	CC		Steel Washer (Φ16*Φ8.2*1.0)	8
D		Foot Cap	6	DD		Steel Washer (Φ12.5*Φ8.5*2)	4
				EE		Bolt cap (19*16.5*17)	4
				FF		Bolt cap (19*16.5*9)	4
				GG		Steel Washer	4
				HH		Wrench	2

GL2A-5576-11KD  
Made in China

## STEP 1

Hand Tighten Nut 3-4 Revolutions Only. Ensure the base is Centered, then adjust all the parts to correct position. Then Tighten All The Bolts And Nuts. Do Not Over Tighten.

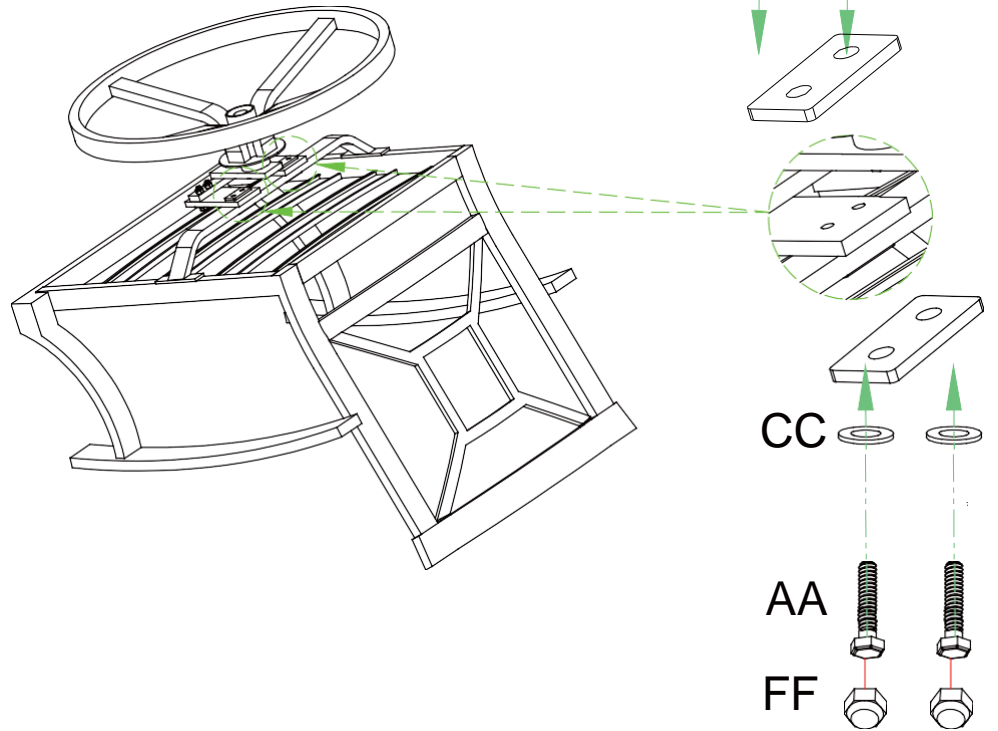

## STEP 2

Need Two People Turn The Chair Right Side Up. Then Put The Cushion On The Chair, Your Chair Is Ready For Use.

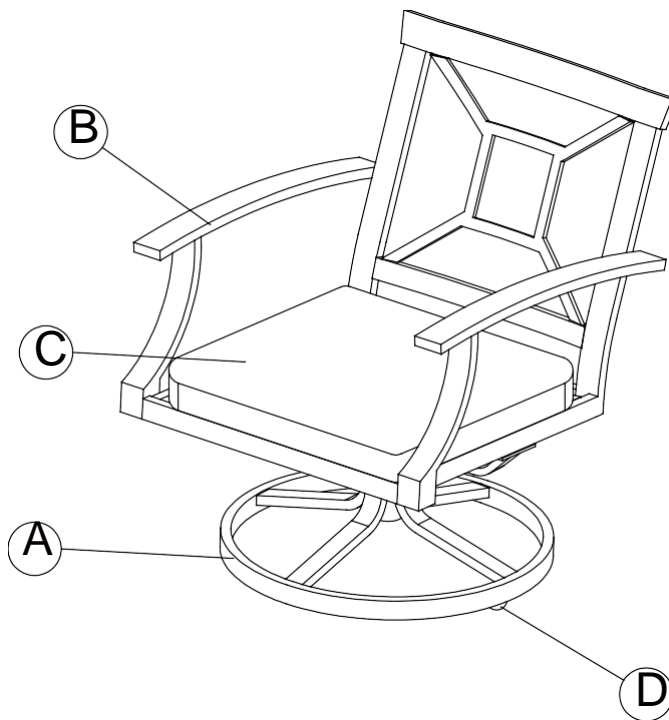

2

\*DO NOT OVER TIGHTEN

\*NO SOCKET DRIVERS



\*NO POWER TOOLS

