

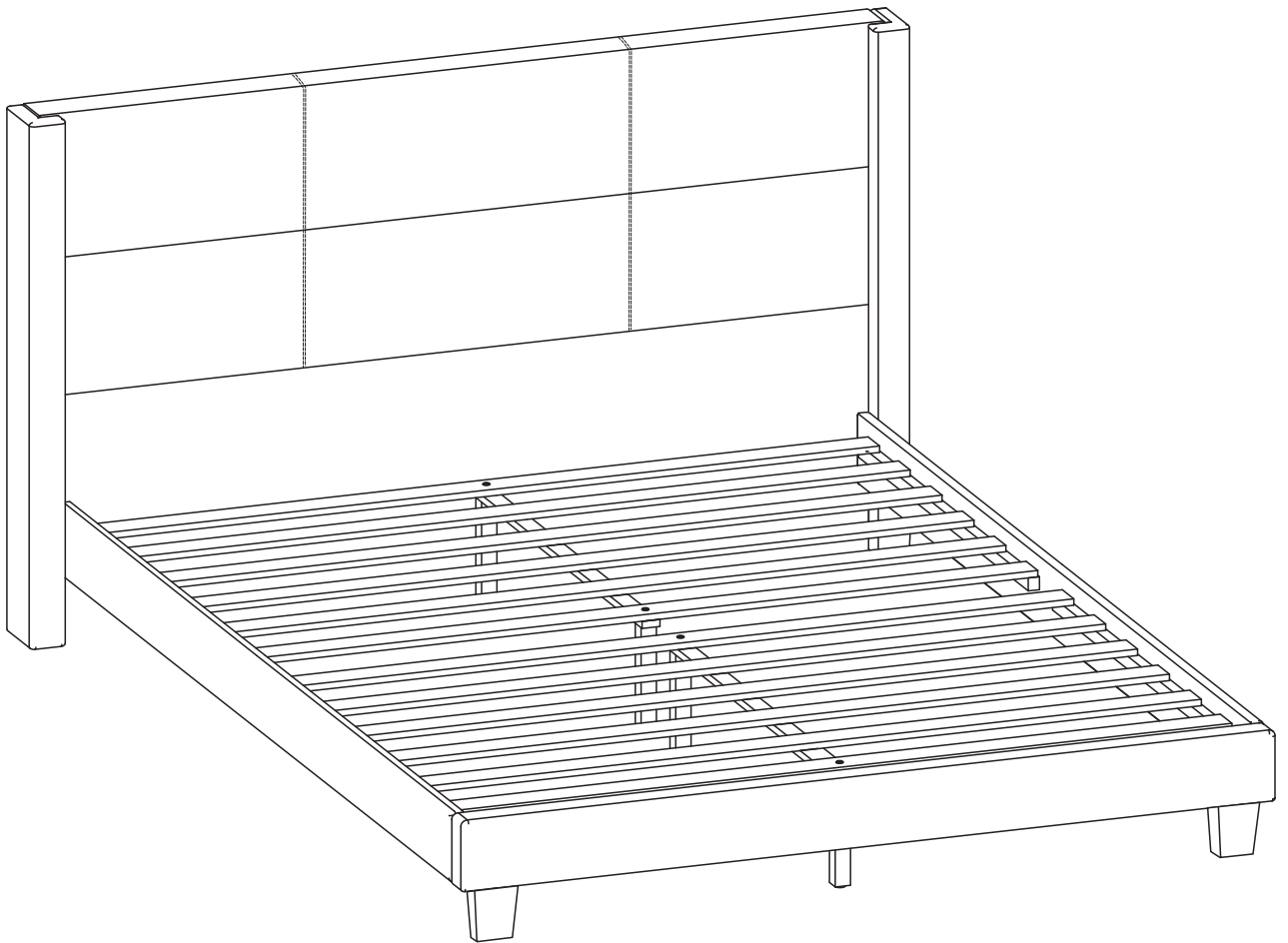

REV 05



32115 Queen Bed

PLEASE CONTACT US FOR QUESTIONS

Email our support team: help@ovis.co

CAUTION:

Do not attempt to slide the bed once it is fully assembled. To avoid structural damage while moving your assembled bed, any mattress and bedding should be removed from the bedframe. Then the bedframe should be lifted and carried (not slid) to your desired location.

When placing furniture on non-carpeted flooring, we recommend the use of floor protection such as an area rug or furniture pads. Area rugs and padding not included with purchase.



Estimated Time for Assembly

25:00 - 35:00



Weight Limitation

600 lbs

Additional Tools Needed – Phillips Screwdriver.

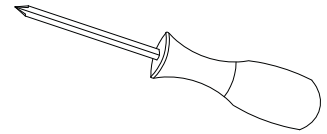

Bed Parts are shipped inside a compartment
in the back of the headboard.

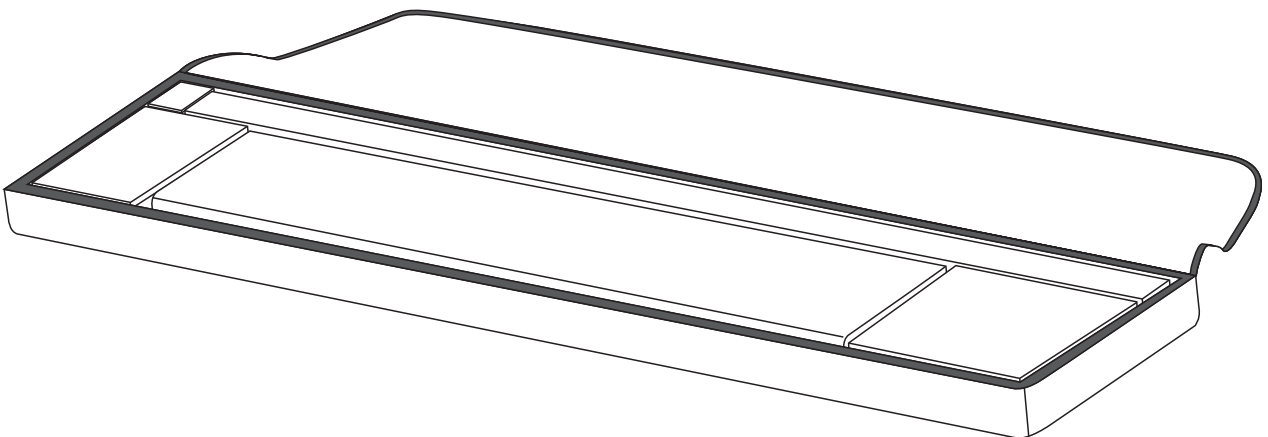

PLEASE CONTACT US FOR QUESTIONS

Email our support team: help@ovis.co

Remove parts from headboard compartment

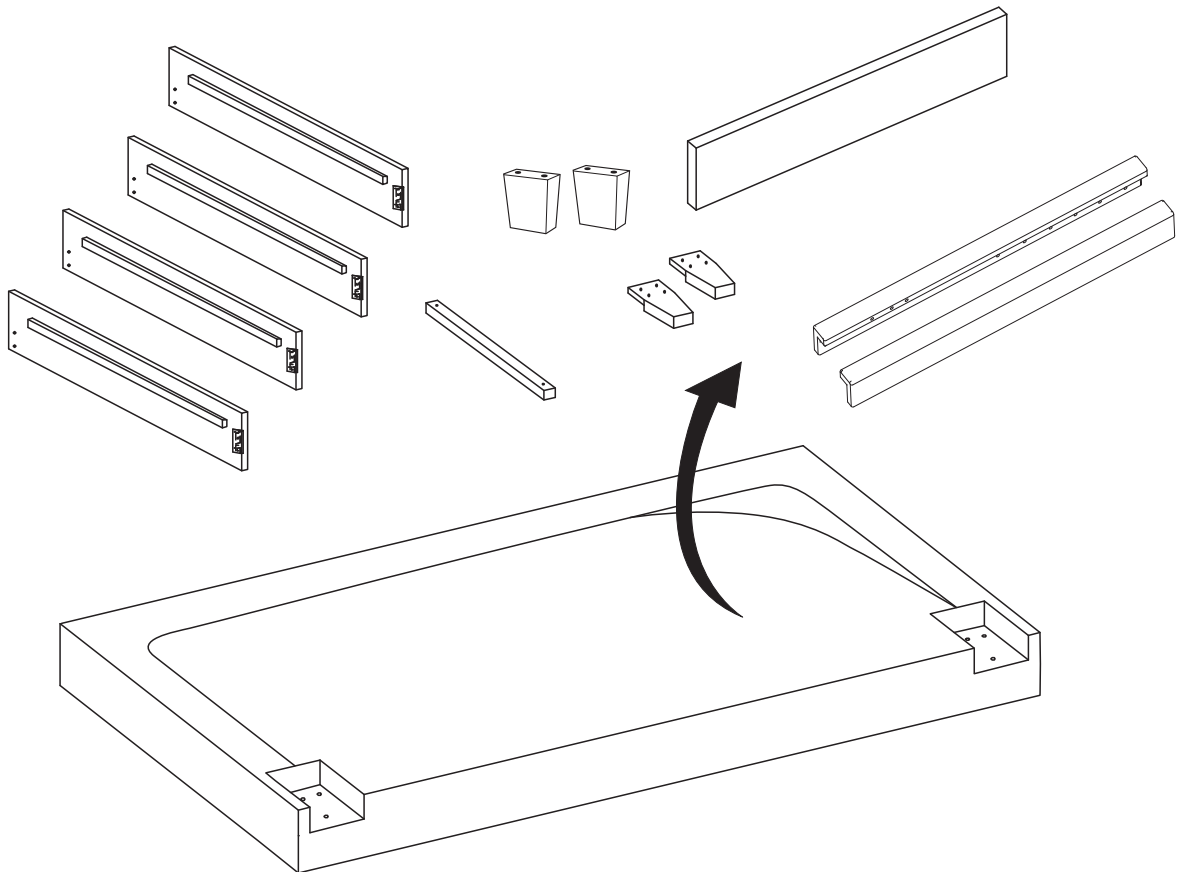

PACKAGE CONTENT

CAUTION:
DO NOT SLIDE BED AFTER
ASSEMBLY. LIFT THE BED FRAME
INTO ITS FINAL POSITION.

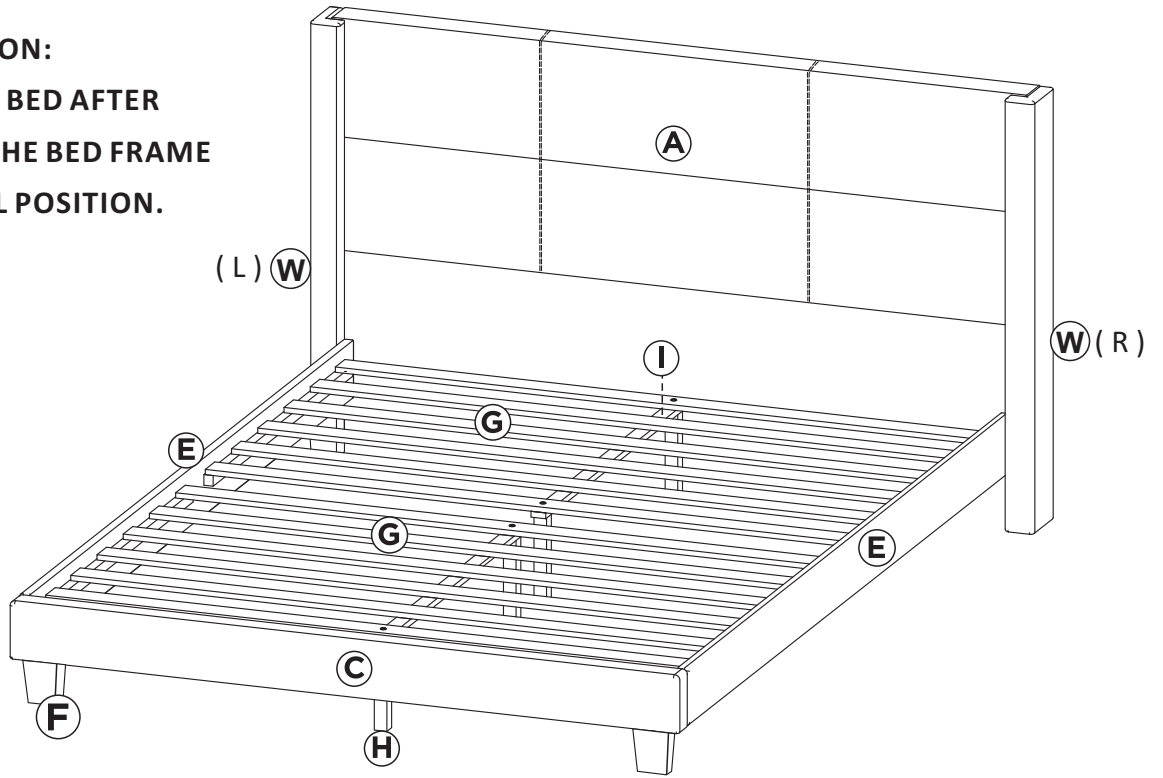

Queen BED

Components

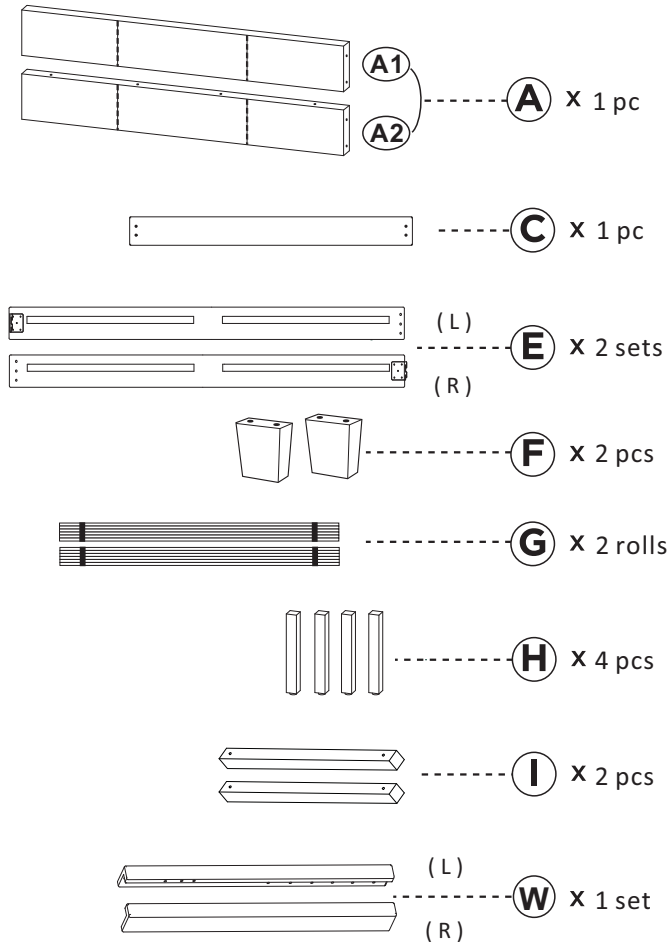

Hardware

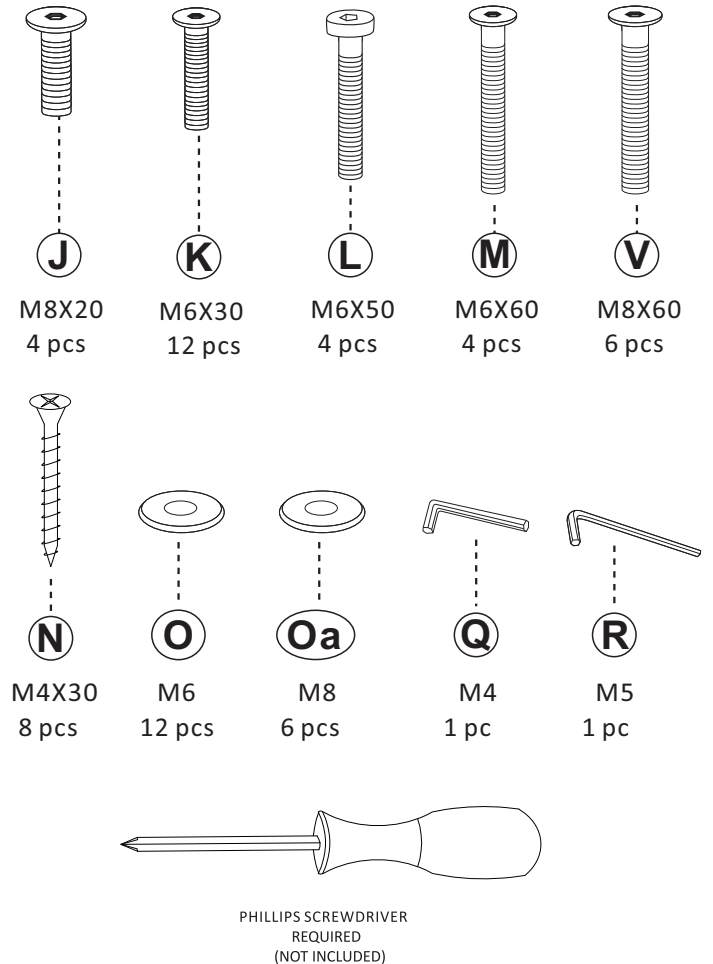

1.

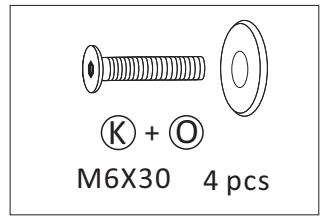

Attach "O" washers to the "K" bolts. Use the assembled "K" bolts to connect the three parts of the headboard A1, A2 together. Take special care to place A1, A2 in the order show in the illustration below. Headboard will not assemble properly if A1, A2 are in incorrect order. Tighten the "K" bolts.

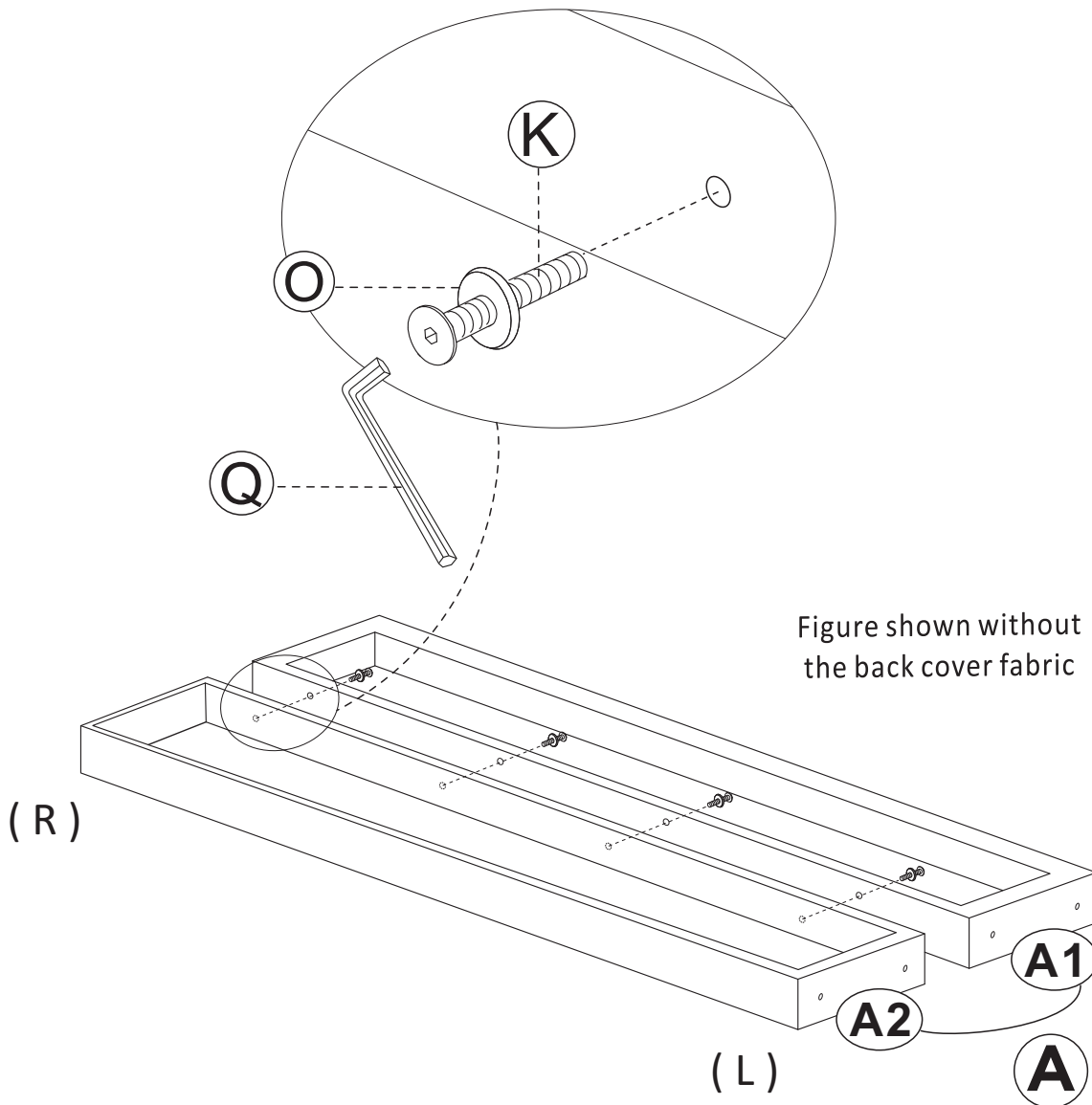

2.

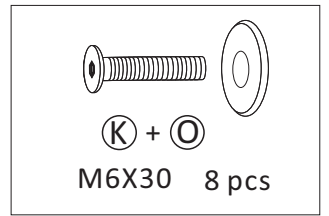

Attach "O" washer to "K" bolt. Use the "K" bolts to connect the wing "W" to the ends of the headboard A1 and A2. Tighten the "K" bolts.

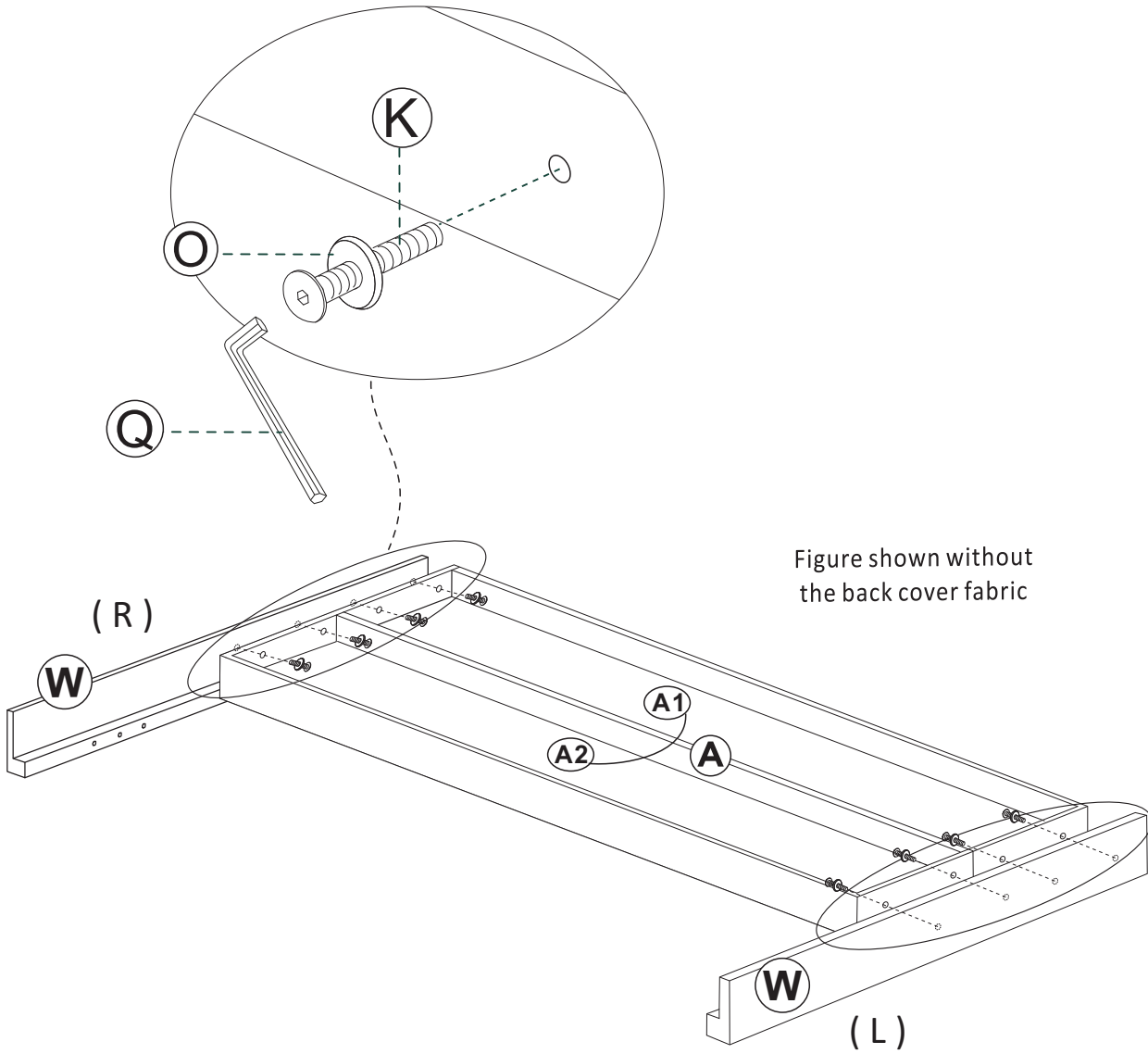
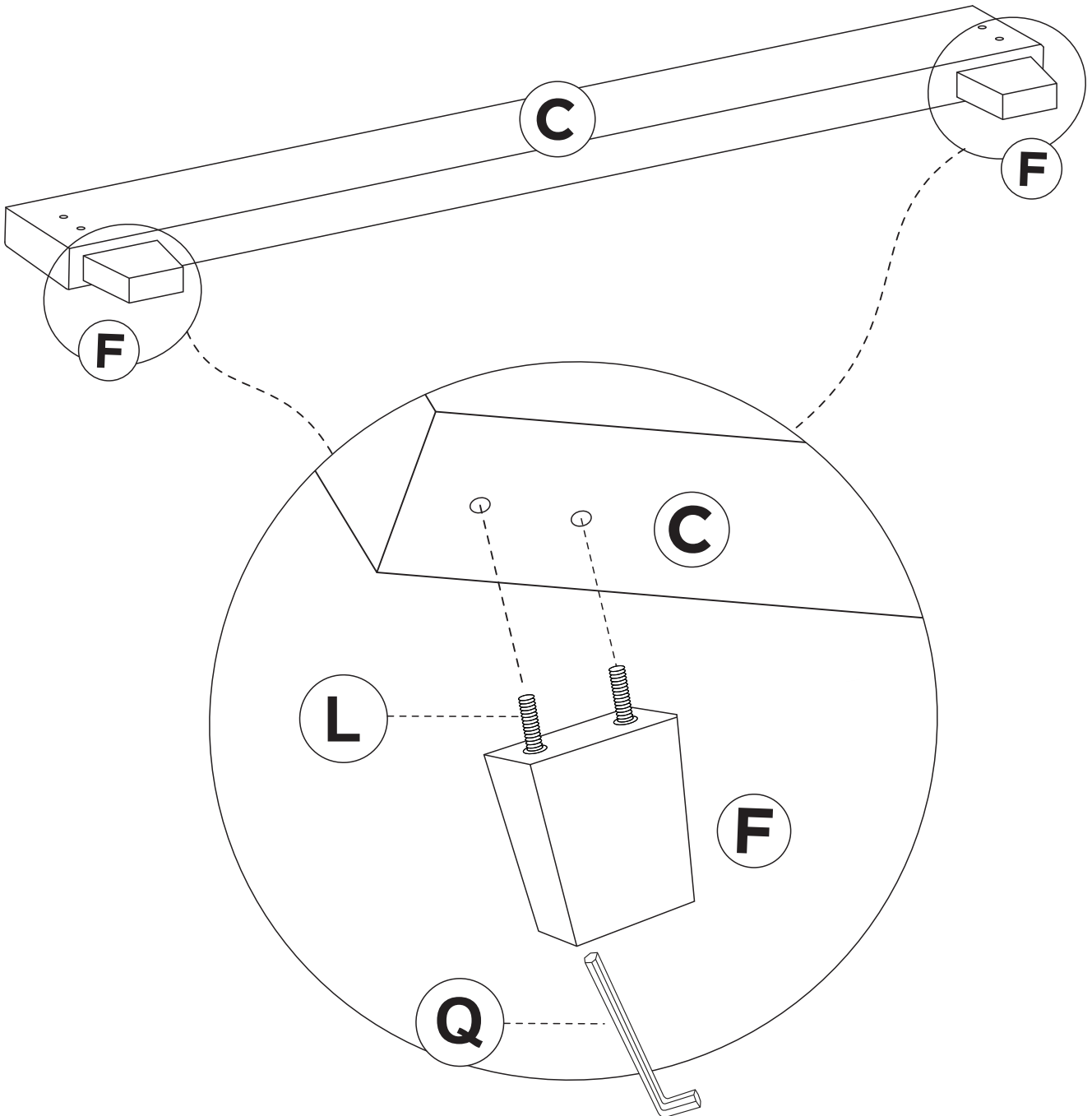
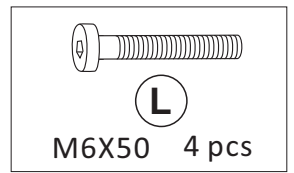
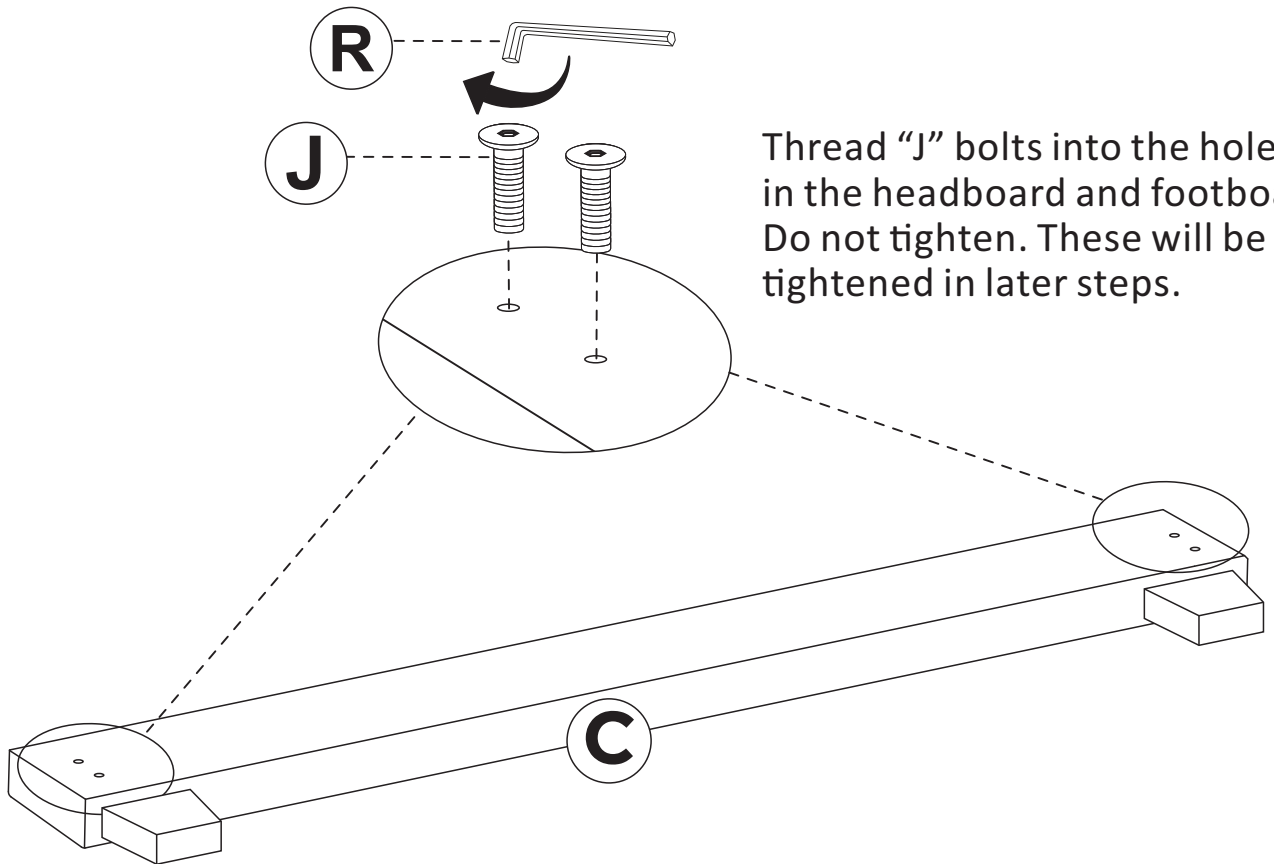
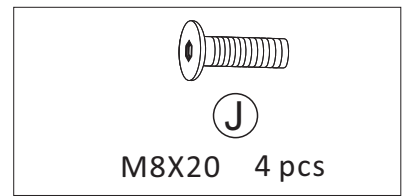

Figure shown without
the back cover fabric

3.



4.



5.

Hang the hooks at the ends of the side rails onto the "J" bolts in the footboard. Tighten the "J" bolt so the rails are secure.

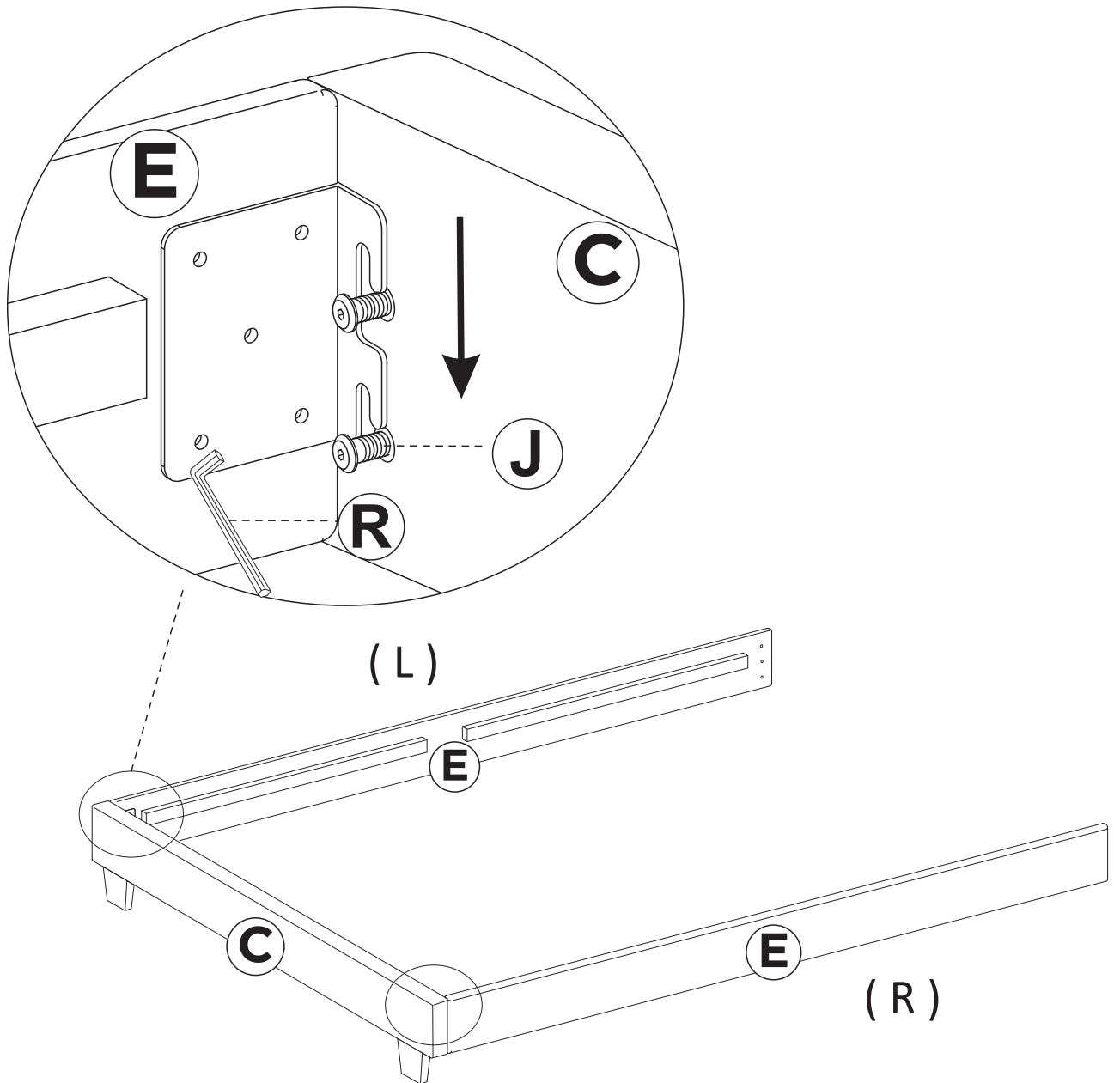

6.

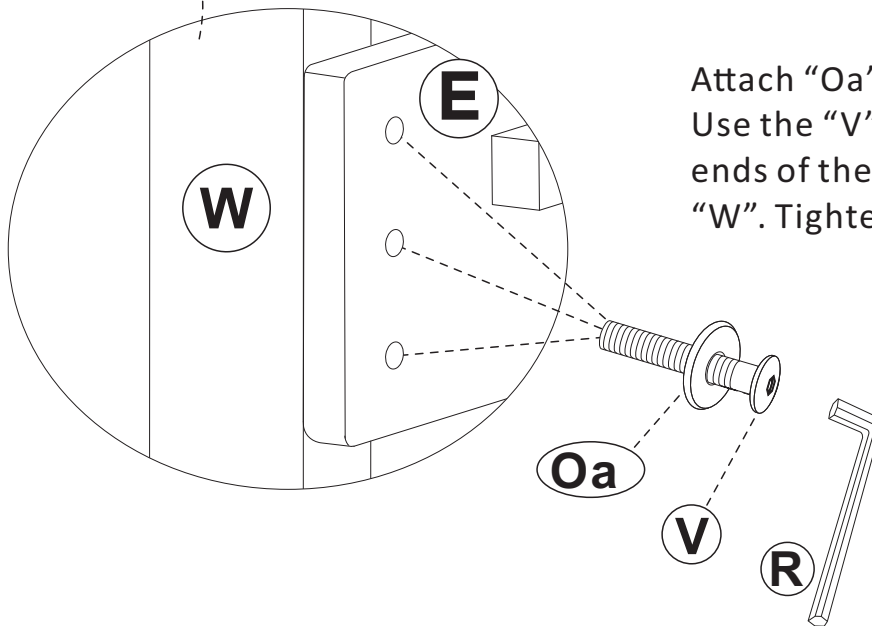
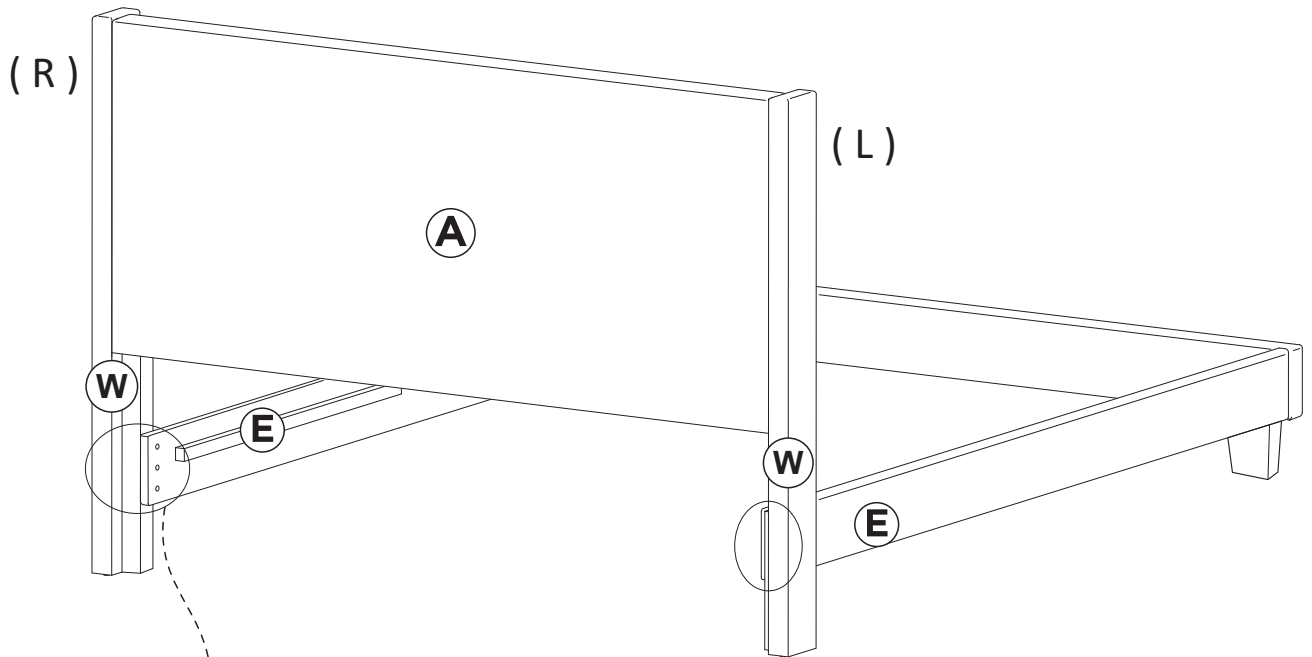
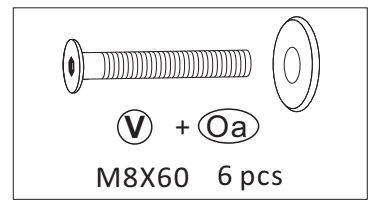

Attach "Oa" washer to "V" bolt.
Use the "V" bolts to connect the
ends of the side rails to the wings
"W". Tighten the "V" bolts.

NOTE:

Do not attempt to slide the bed once it is fully assembled. Sliding the bed could result in damage to the rails, headboard, or footboard.
Assembled bed should be lifted and carried when being moved. (not slid)

7.

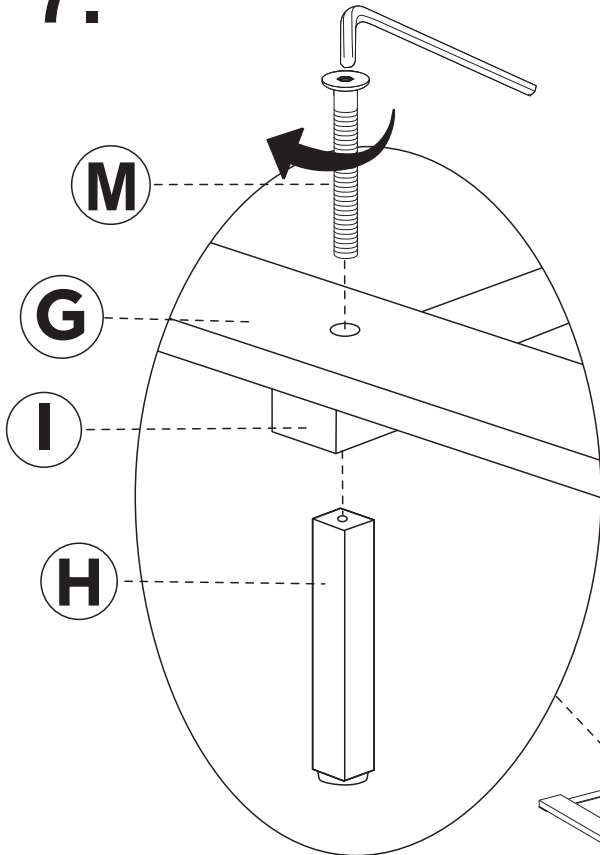
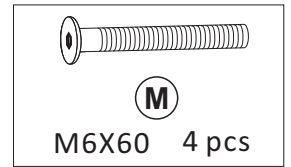

Assemble the slat system by attaching the slats "G" to the "I" supports and "H" legs. First, extend the slats. Then, line up the holes in the slats with the holes in the "I" supports and the holes in the tops of the "H" legs. Use an "M" bolt through the holes to attach them together.

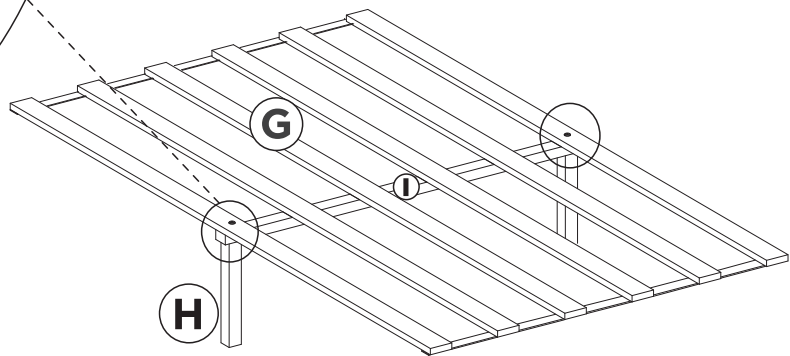

Repeat steps to assemble the second roll slat.

After the slat system is assembled, place the slats into the frame of the bed, and velcro the slats to the cleat of side rail as shown below.

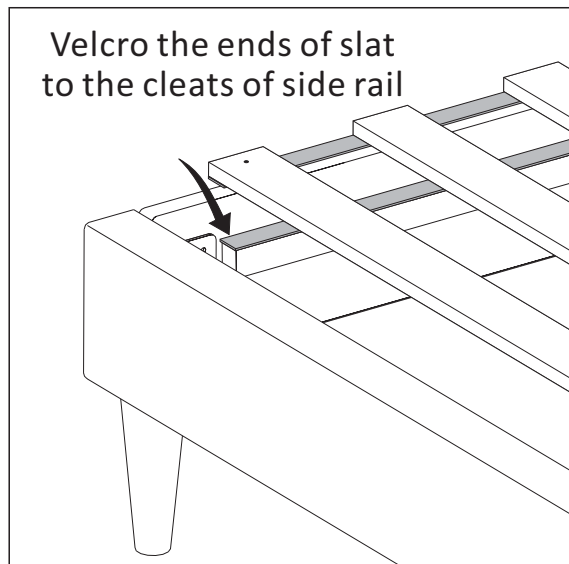

8.

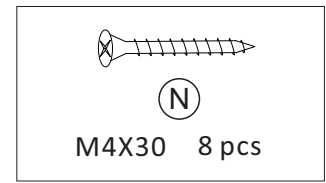

NOTE:

The center support leg glide sits approximately 1/4" off of the floor. The glide will touch the floor after a mattress is placed on the bedframe.

Do not place a mattress on bedframe until it is fully assembled and the bedframe located in your desired location. Sliding the bed with weight upon it can compromise the integrity of the center support legs.

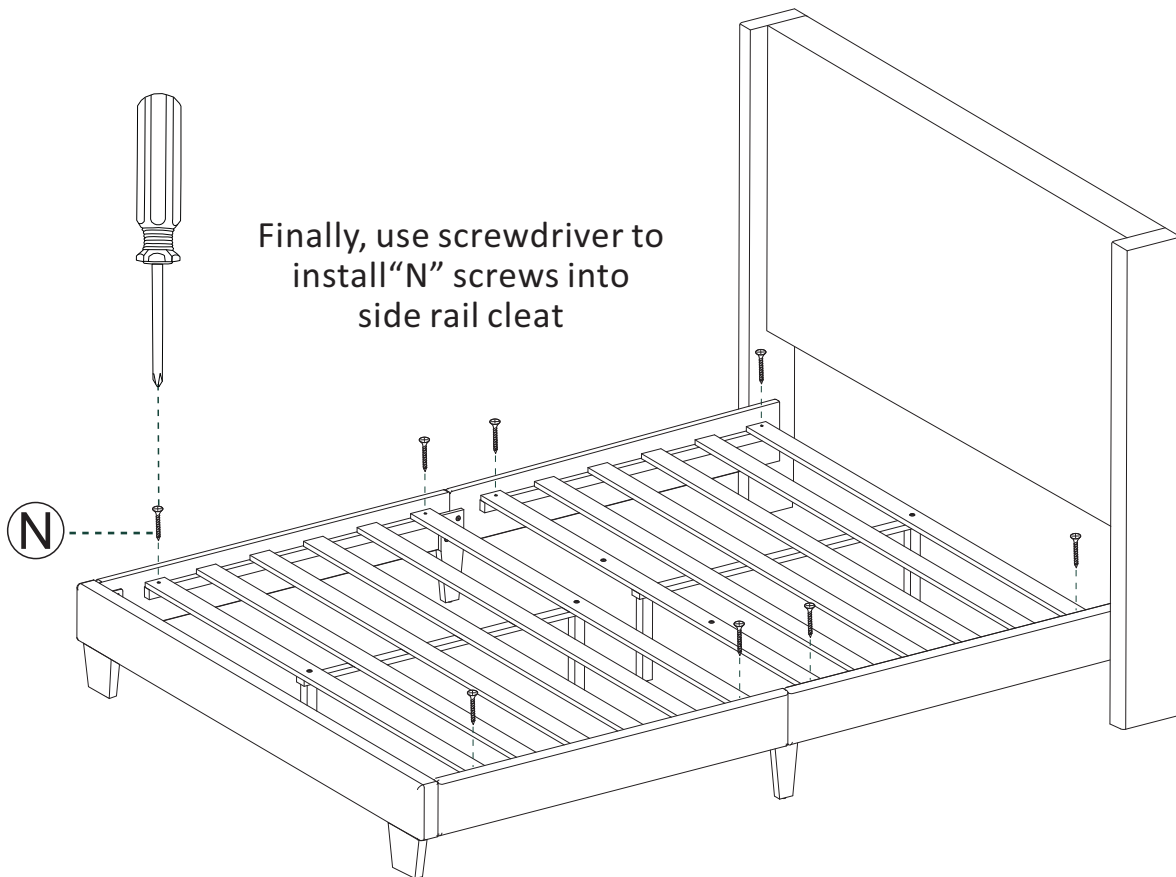
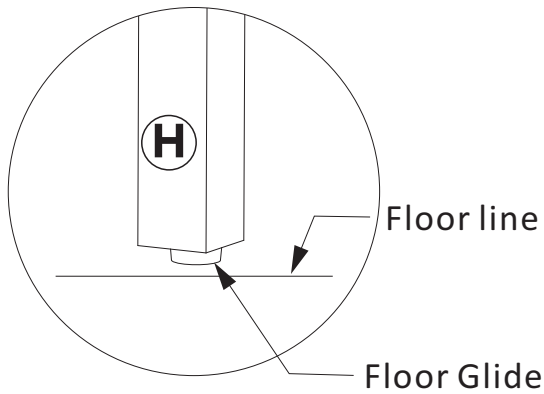

NEED ADDITIONAL HELP?

Email our support team: help@ovis.co