

ASSEMBLY INSTRUCTIONS

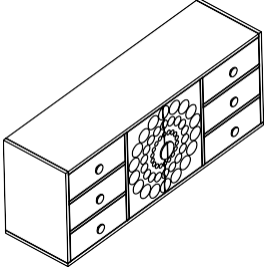
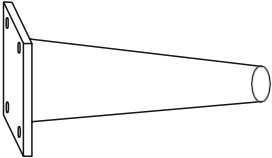

ITEM NO. 77262

Thank you for purchasing this quality product. Be sure to check all packing material carefully for small parts, which may have come loose inside the carton during shipment. Identify and count all parts and compare with the hardware and parts list below.

Part List

Label	Picture	Description	Qty.
A		SIDEBOARD	1 PC
B		LEG	4 PCs

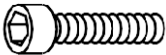
Hardware List

Label	Picture	Description	Size	Qty.
H-1		BOLT	6 x 20 mm	16+1 PCs
H-2		FLAT WASHER	15 mm	16+1 PCs
H-3		SPRING WASHER	15 mm	16+1 PCs

Tool List

Label	Picture	Description	Size	Qty.
T-1		ALLEN KEY	4 mm	1 PC

ASSEMBLY INSTRUCTIONS

ITEM NO. 77262

PROCESS- Carefully remove all parts from the carton. Place the sideboard upside down on a flat surface. Align the iron legs into position. Insert one spring washer, flat washer and bolt at each side to attach legs and tighten all by provided allen key.

STEP - 1

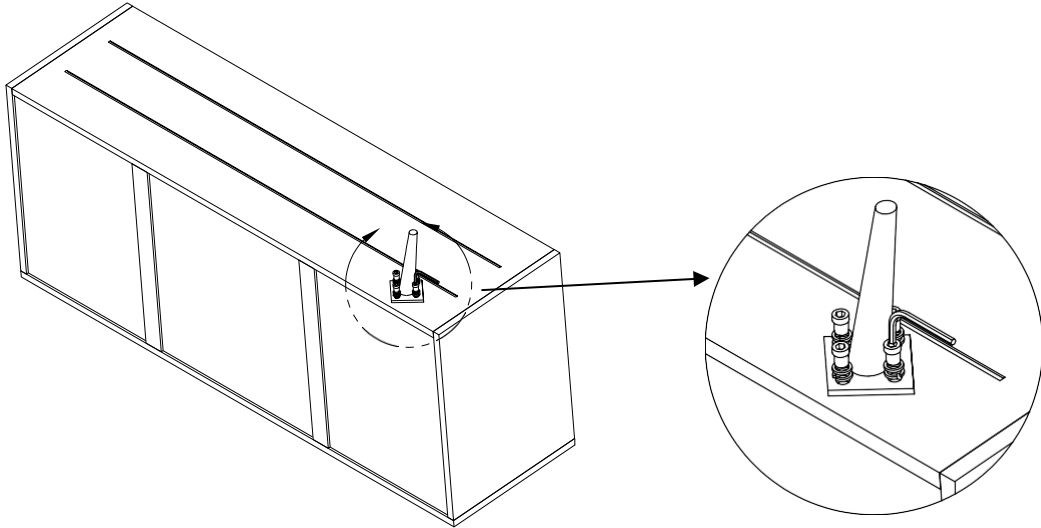

STEP - 2

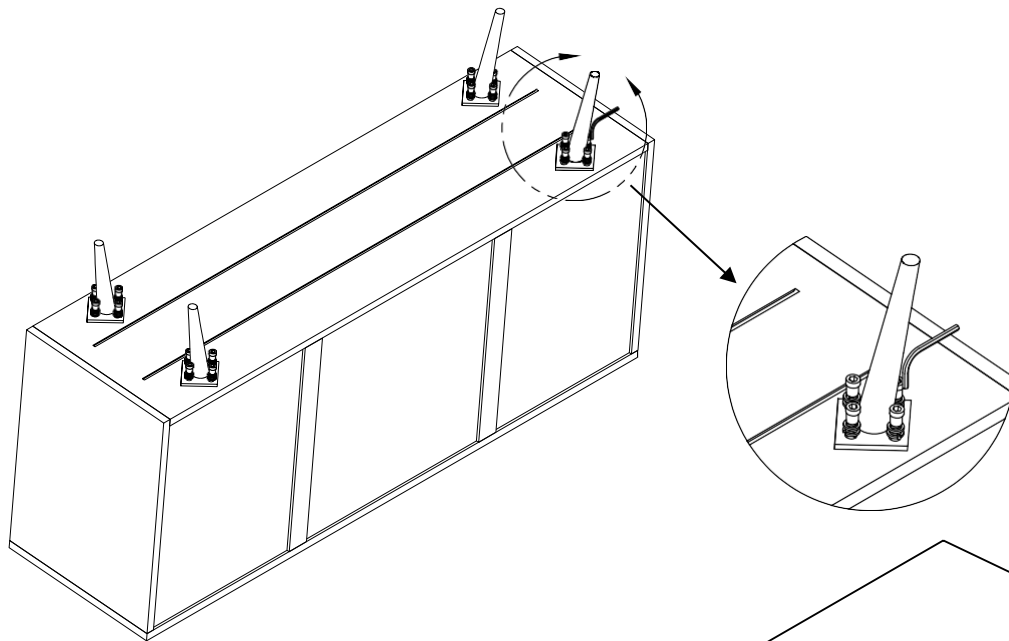

STEP - FINAL

