

# ASSEMBLY INSTRUCTION

## SKU# 77241

**Before beginning**

- Unpack all parts and hardware to ensure you have all needed components for assembly.
- Read this guide cover before beginning assembly .
- Assemble this item on a soft surface such as carpet to protect finish.
- Proper assembly of this item requires 2 person & 20 minutes to assemble.

**CARE INSTRUCTIONS**

Wipe with a soft and dry cloth. To protect finish, avoid the use of chemicals and household cleaners. Any liquid in the table should be cleaned up immediately with a damp cloth.

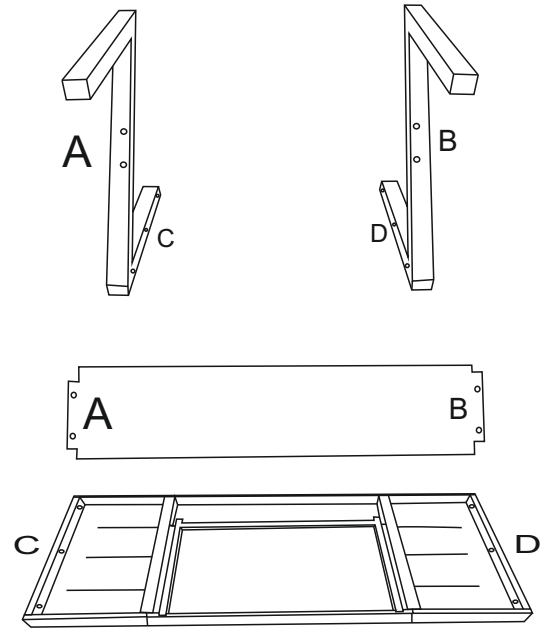

**HOW TO ASSEMBLY**





STEP-1 Place the writing table top upside on rug and match marking A with A & B With B respectively.

STEP-2 Insert allen bolt F with spring washer H and flat washer G then tighten with allen key E.

STEP-3 Match marking C with C and D with D respectively.

STEP-4 Insert allen bolt F with spring washer H and flat washer G then tighten with allen key E.

STEP-5 Turn the writing table down writing table ready to use.

No.	Sketch	Description.	Size (IN)	Qty.	Ext.
E		ALLEN KEY	0.19"	1	0
F		ALLEN BOLT	0.31X1"	18	1
G		WASHER	0.35X1"	18	1
H		SPRING WASHER	0.35X0.5"	18	1

### Step - 1

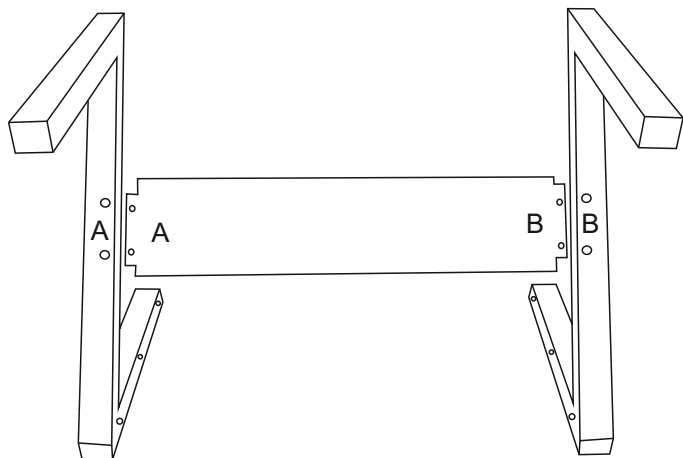

Tip for leveling of product:  
When the product rests on an uneven floor surface  
it will appear to be unbalanced. To aid in leveling, try  
adjusting the levelers on the bottom of each foot.

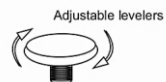

### Step - 2

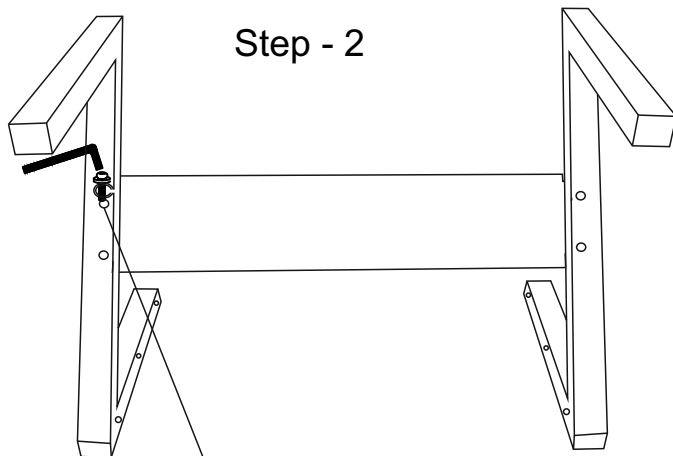

### Step - 3

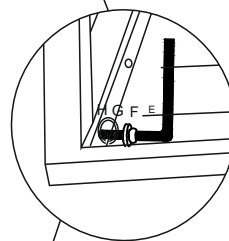
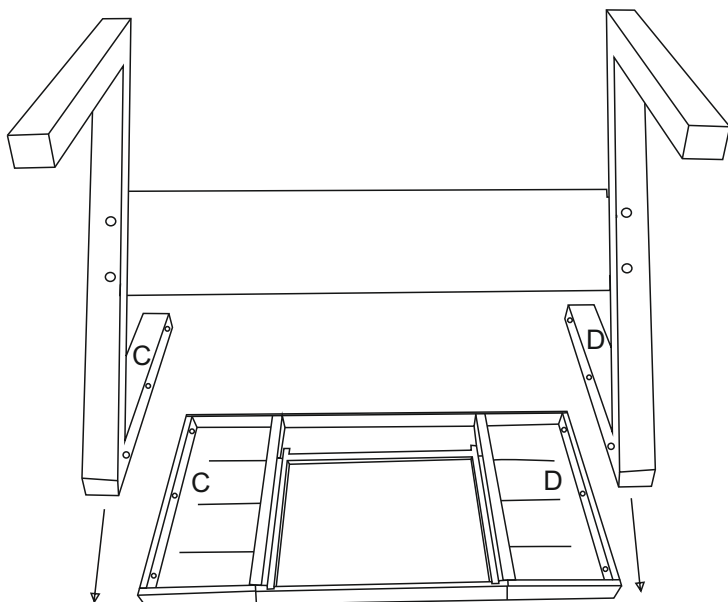

### Step - 4

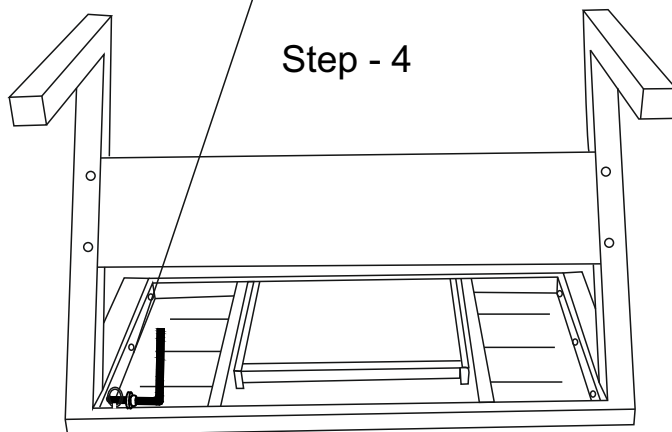

### Step - 5

