



# ASSEMBLY INSTRUCTIONS

ITEM NO.: I792-08  
RECTANGULAR PLANTER WITH METAL LEGS

Thank you for purchasing this quality product. Place all wooden parts on a clean and smooth surface such as a rug or carpet to avoid the parts from being scratched. Be sure to check all packing materials carefully for small parts may have come loose inside the carton during shipment, clarify and count all parts and compare with the parts list below. Do not tighten all screws / bolts until all completely assembled.

Parts List		
No.	Description	Q.ty
A	Wooden Part	1PC
B	Planter leg	4PCS
C	Connector	1PC
D	Plastic Pot	1PC

Hardware List				
No.	Description	Sketch	Size	Q.ty
1	Allen Key		M4	1pc
2	Screws Chrome		3.5 x 12 mm	4pcs
3	Screws		3.5 x 15 mm	8pcs

### NOTE : YOU WILL ALSO NEED A SCREWDRIVER (NOT PROVIDED)

These parts are cumbersome and heavy. Therefore, two people are recommended in order to prevent personal injury and insure the parts are not damaged during the assembly.

#### Important Notes

- \*Keep all hardware parts out of reach of children!
- \*Tighten screws periodically! With the use of this product bolts and screws may become loose over time!
- \*Don't attempt to modify parts!

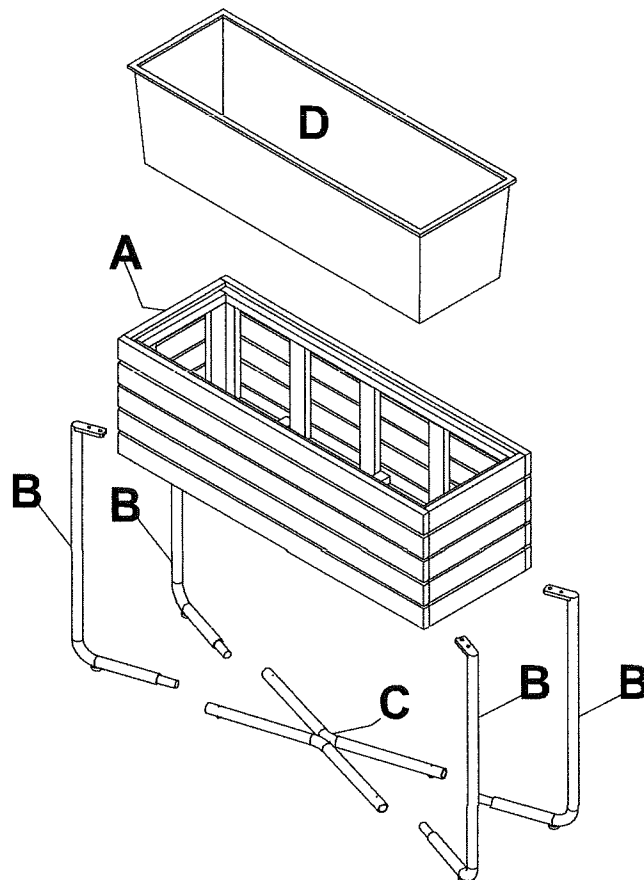

# ASSEMBLY INSTRUCTIONS

ITEM NO.: I792-08  
RECTANGULAR PLANTER WITH METAL LEGS

**STEP 1:** Do not fully tighten the bolts until all parts have been assembled

**Screws (2) x 4** Chrome self tapping screws

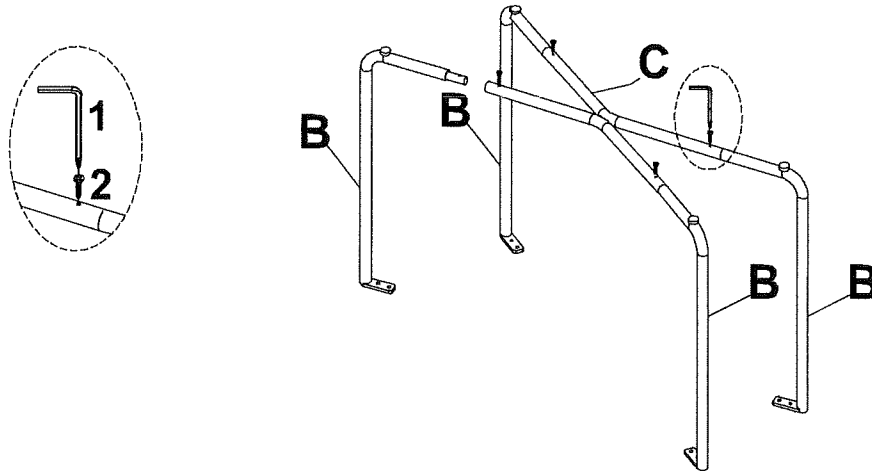

## **STEP 2:**

Installation wooden part and leg by screws.  
Using the Allen key to tighten all screws.

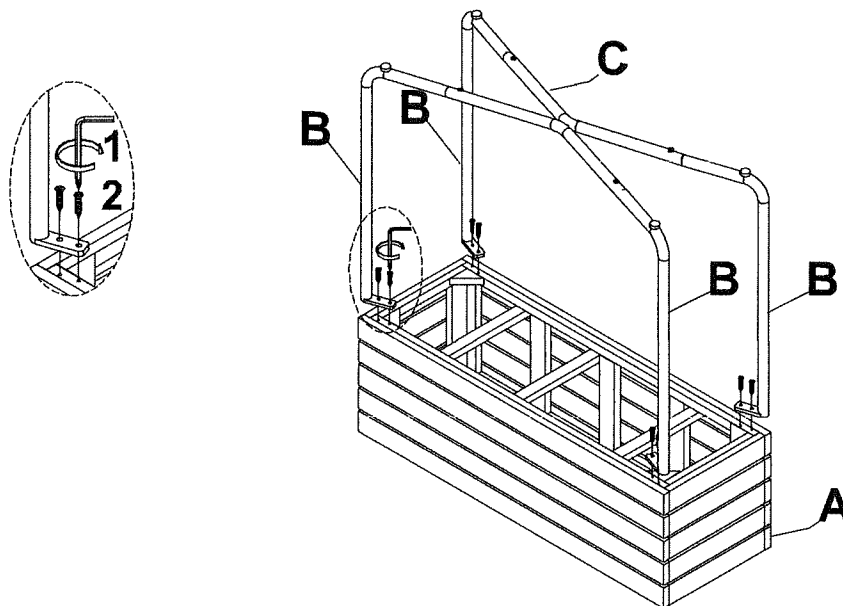

**Screws (2) x 8**

# ASSEMBLY INSTRUCTIONS

ITEM NO.: I792-08  
RECTANGULAR PLANTER WITH METAL LEGS

## STEP 3:

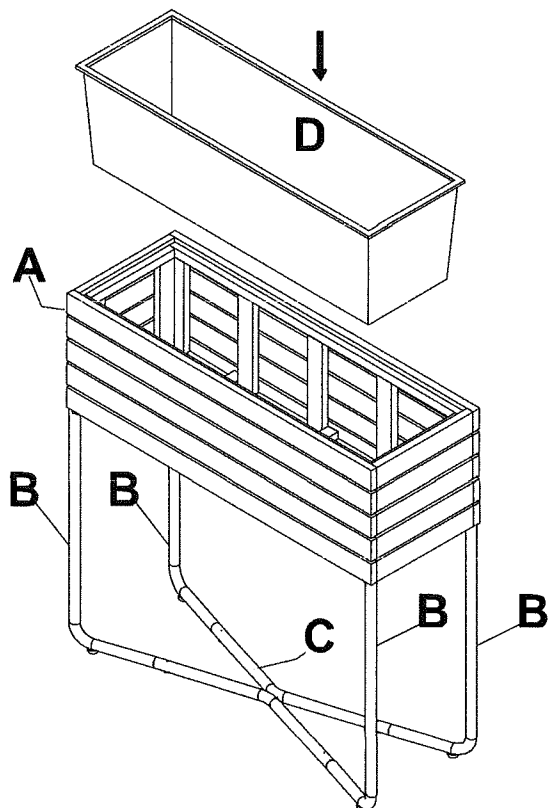

## STEP 4:

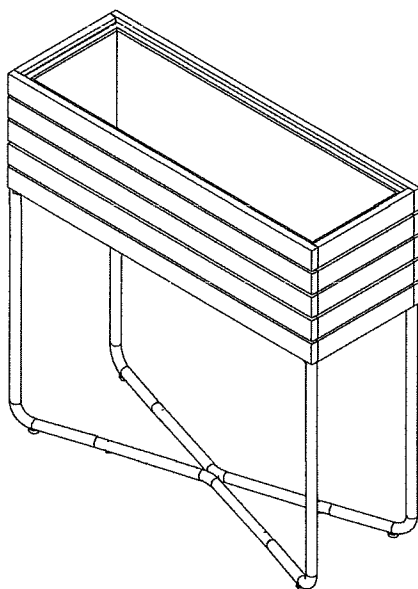

Cleaning instruction: Clean using soft cloth

Made in Vietnam