

 TREASURE GARDEN

User Guide

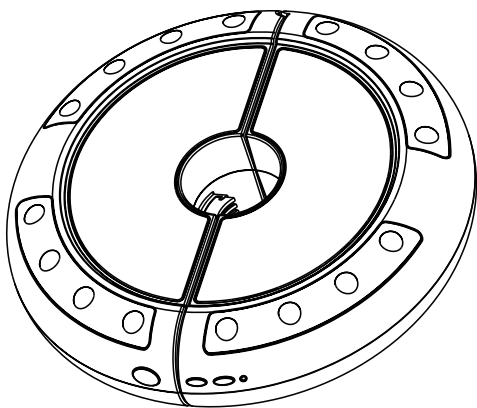

LUNA



LUNA *Umbrella Light
with Bluetooth® Speaker*

Thank you for purchasing Treasure Garden's Luna Umbrella Light.
Please remove all contents from the package, inspect and review checklist.

CHECKLIST

A - (1) Luna

B - (1) Power Supply*

A -

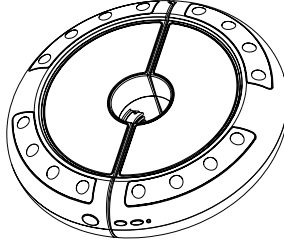

B -



*Note: Use only the Power Supply included with Luna. See page 6 for Safety Precautions. ⚠

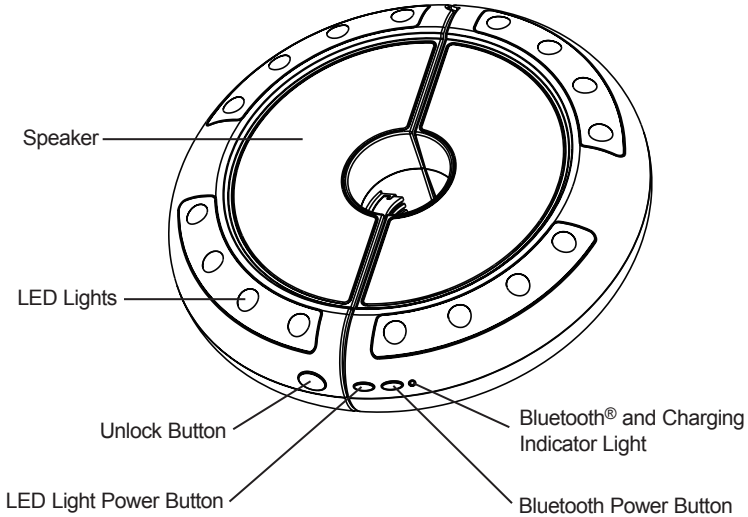

Back View

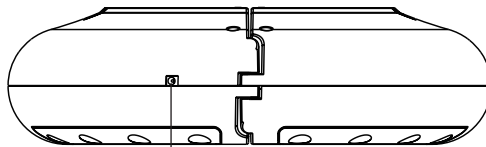

Charging Port

STEP 1 CHARGING

- Connect the power supply to the Luna charging port , then plug the other end into any 110V power source. Charge Luna for 2-4 hours. The Luna is fully charged when the Bluetooth indicator light turns off.

Note:

- Charge Luna in dry area to keep from damaging.
- We recommend fully charging Luna before you store for extended periods of time.
- When the Luna battery is low, you will hear an indicator tone notifying you to charge the Luna.

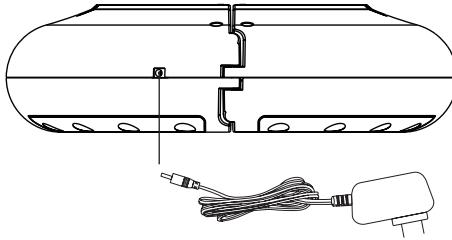

STEP 2 PAIRING BLUETOOTH DEVICE

- To turn on Bluetooth, locate the Bluetooth power button on the Luna. Press and hold Bluetooth power button for 3 seconds until you hear a prompt sound. The Bluetooth indicator light will blink blue when in pairing mode.
- From your music device, turn on Bluetooth and switch your device to discovery mode. Select "LUNA" from your device options. You will hear a set tone and the Bluetooth light will become solid blue once the Luna and your music device are paired successfully.
- Use controls on music device to select songs from playlists and adjust volume.

Note:

- Sound quality will lessen or music will stop playing when music device is approximately 30 feet away from Luna.

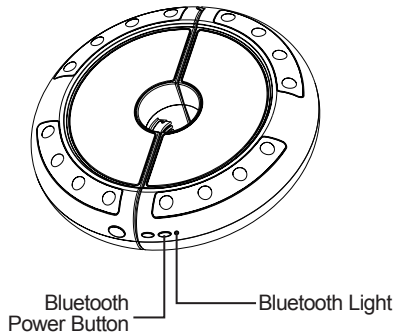

STEP 3 UNPAIRING BLUETOOTH DEVICE

- Only 1 music device can be connected at a time.
- To pair another device, first unpair the current device by disconnecting Bluetooth on device, or pressing and holding the Bluetooth power button for 2 seconds. You will hear a tone when the current music device unpairs and the Bluetooth light will begin blinking blue again.

Note:

- If you hold Bluetooth power button for 4 seconds, the device will shut off.

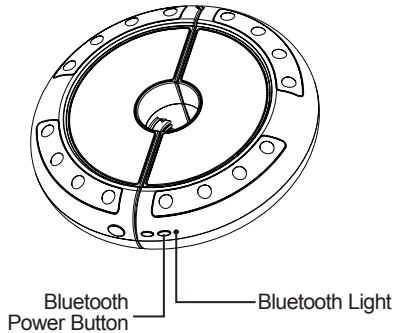

STEP 4 TURNING DEVICE OFF

- To turn off Luna, press and hold Bluetooth power button for 4 seconds. You will hear a descending tone and the Bluetooth Indicator light will turn off.

Note:

- Luna will turn off automatically when Bluetooth is in pairing mode, or inactive for more than 15 minutes.
- When your music device is disconnected, you will hear a prompt sound from Luna.

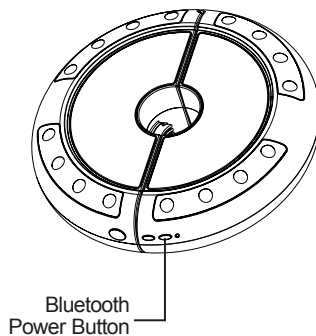

STEP 5 LED LIGHTS

- To turn on and off LED lights, press the LED light power button.

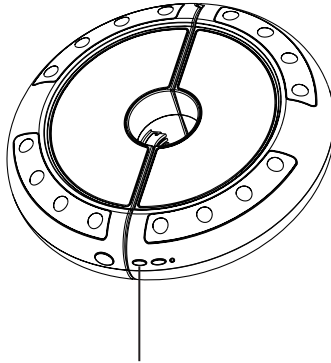

LED Light Power Button

STEP 6

ATTACHING LUNA TO UMBRELLA

- The Luna can be attached to umbrella center poles up to 2" and cantilever umbrella light adapters.
- Open Luna by holding the device firmly with one hand and then press "unlock" button with the other hand to release the clamp lock.
- Open up the Luna light and clasp around the mid pole or light adapter. Snap to close.

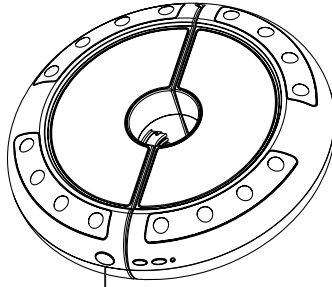

Unlock Button

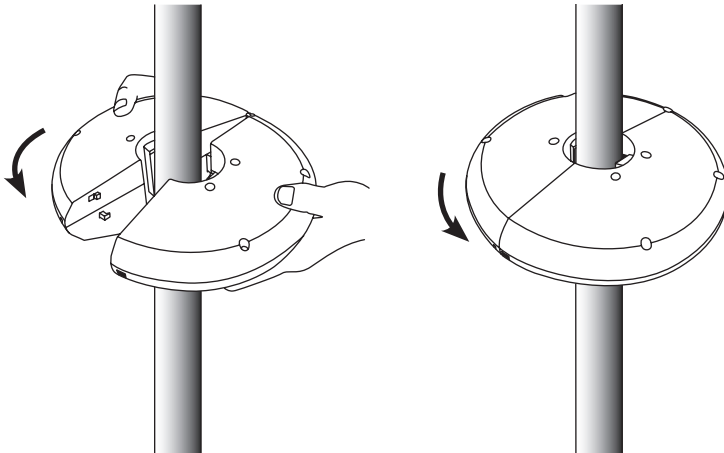

SAFETY PRECAUTIONS

- Position Luna in a location that will protect it from direct sunlight and moisture.
- Do not overcharge the battery. Unplug the power supply when the indicator light turns off. Over charging may cause the battery to become hot, rupture or ignite. If you see any heat deformation or leakage, properly dispose of the device.
- If unit is exposed to light moisture, allow unit to air dry for a minimum of 24 hours before reuse.
- Power supply must be used indoors only. It is neither designed nor tested for use outdoors.

WARNING: *The Luna umbrella light is not waterproof.* If Luna is immersed in water or exposed to heavy rain the unit will be damaged and void the 1 year warranty.

NOTE: We recommend fully charging Luna before you store for extended periods of time.

Power Supply:

- Never use a third party battery or power supply. Doing so may increase risk of fire or explosion. Contact your local authorized dealer for a replacement power supply.
- During prolonged use, it is normal for the power supply to be warm to the touch. When using power supply, avoid direct sunlight and exposure to moisture.
- Do not attempt to charge the Luna in inclement weather (rain, snow) so as to prevent damage to the electrical components.

Power Supply Information

Input voltage: 100-240Vac 50/60Hz

Output: 9VDC 1.2A

5' Cord



The Bluetooth® word mark and logos are registered trademarks owned by Bluetooth SIG, Inc. and any use of such marks by Treasure Garden is under license. Other trademarks and trade names are those of their respective owners.

WARRANTY:

Treasure Garden warrants this product (for residential use ONLY) to be free from defects in original materials and workmanship for a period of 1 year from the date of purchase. If a defect in the original material or workmanship appears during the warranty period; Treasure Garden will (at its discretion) repair or replace the product without charge.

Simply contact your original authorized Treasure Garden dealer with a description of the defect. The dealer will verify the defect and work closely with Treasure Garden to obtain the necessary service. In many cases, simple problems can be solved with a replacement part that can be shipped directly to the dealer for professional installation / repair.

There are no serviceable parts within this product, DO NOT OPEN. Tampering with or altering the product will void warranty.

In the event that warranted factory service

is required, Treasure Garden will assume the responsibility of the return freight charges for the first year only.

Returned product that (upon receipt and inspection) is deemed to be "not covered" under our warranty, will be shipped / billed at your expense.

This warranty gives you specific legal rights, and you may have other rights which vary from state to state.

RUST: Rust is a natural part of the aging process of steel or iron based materials, and is therefore NOT considered a defect.

NOTE: Failure caused by unreasonable or abusive use, or failure caused by neglect of reasonable and necessary care are not covered by this warranty.

Additionally, acts of nature (including but not limited to wind, hurricanes, tornadoes, and storms) are not covered by this warranty.



www.treasuregarden.com

©2020 Treasure Garden, Inc. - All Rights Reserved.
v.07.08.20